

IS125 Conveyors

Installation & Maintenance Instructions



Contents

Warnings	2
Required Tools	3
Installation	4
Drive Packages	16
Maintenance	25
Recommended Spare Parts	32
Exploded Views	34
Troubleshooting	33
Warranty Information	38
Service Record	43



QC Conveyors
4057 Clough Woods Dr.
Batavia, OH 45103 USA

+1 (513) 753-6000
qcconveyors.com

Warnings



When used improperly, conveyor rollers can pinch or maim



Lock out power before servicing conveyor

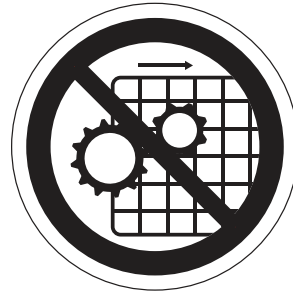

Do not use with guards removed



Read this manual before operating

DANGER

WARNING

WARNING

WARNING



Climbing, sitting, walking or riding on conveyor at any time will cause severe injury or death

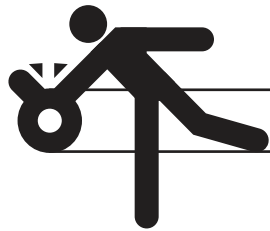

Exposed moving parts can cause severe injury; DISCONNECT POWER before removing guard



Equipment may start without warning - can cause severe injury. KEEP AWAY



Servicing moving or energized equipment can cause severe injury LOCK OUT POWER

Tools

► Required Tools

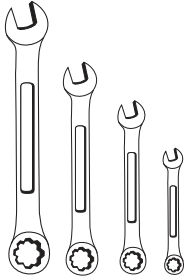

Set of wrenches (1/4" , 5/16" , 1/2" , 9/16", 13mm)

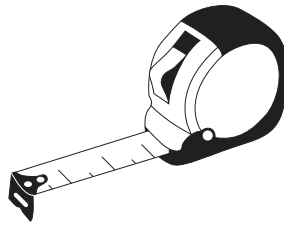

Tape Measure



10" Adjustable Wrench

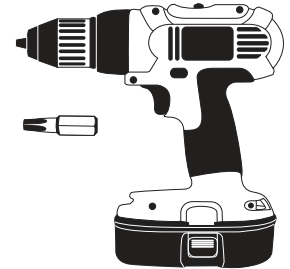

Screw Gun and T-25 Torx Bit

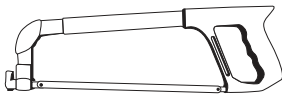

Aluminum and steel cutting hack saw or equivalent

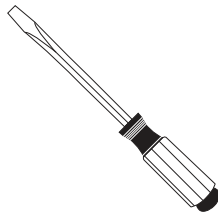

Wide flat head screw driver

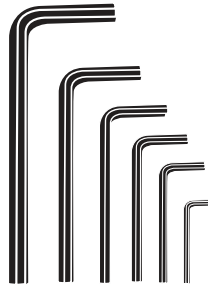

Set of allen wrenches (3/32", 7/64", 1/8", 3/16", 5/32", 1/4")



Bubble level

► Optional Tools

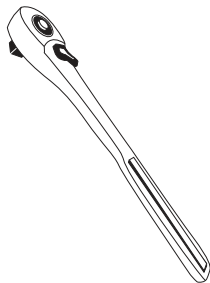

3/8" drive socket wrench

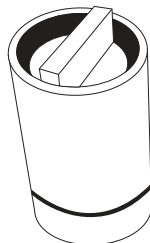

QC Conveyors tail turning tool
Part#: TK-TURNTAIL

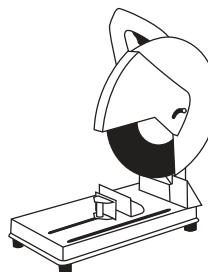

Electric chop saw with proper metal cutting blade

Installation

► Check Your Shipment

Before opening the shipment, visually inspect the outside of the crate/box for shipping damage. Carefully unpack the crate/box, inspecting for component damage which may have occurred inside the packing materials. Contact the carrier and QC Conveyors regarding any damage that may have occurred during shipment. Check the contents of your shipment against the supplied packing slip and inform QC Conveyors of any discrepancies.

► General Sequence of Installation

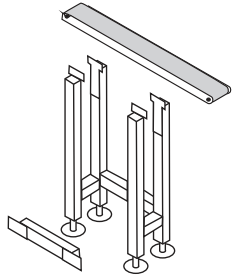

1 Mount conveyor to stands or compatible mounting brackets.

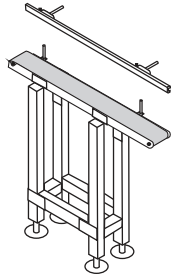

2 Attach sides or guides to conveyor and adjust as needed.

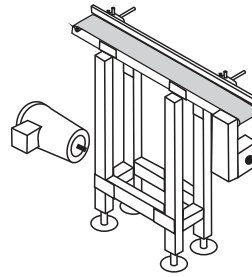

3 Install drive motor and mounting package.

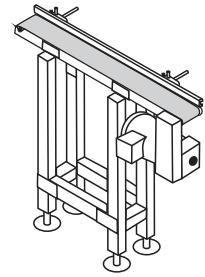

4 Conveyor should be lagged to floor or caster locks engaged before operation.

► Assistance

If you need assistance, please contact QC Conveyors customer service department Monday through Friday, 8am-5pm EST at (513) 753-6000. In addition, your local distributor has been trained at the factory and can provide support in many ways. You can also visit our website – qcconveyors.com – for additional information and technical documents.

Stand Installation

Mounting Aluminum Stands to Conveyor

► Mounting Aluminum Exact Width Stands

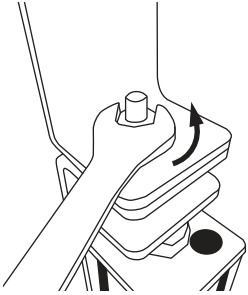

1 Using a 13mm wrench, remove the nuts holding the stand attachment brackets to the top of the stand and remove the brackets.

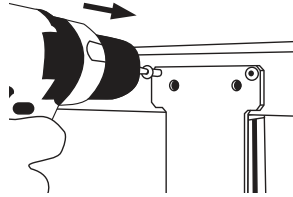

2 Insert torx head thread forming screws through bracket and into accessory holes (2 per side). Flange on stand attachment bracket should point outboard for conveyors 6" wide or less and inboard for conveyors more than 6" wide.

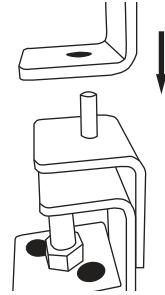

3 Place stand attachment brackets atop stands.

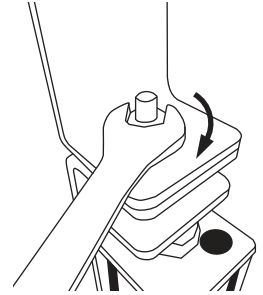

4 Replace nuts and tighten using a 13mm wrench.

► Stand Height Adjustment

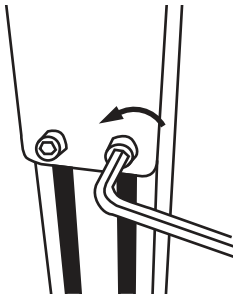

1 Loosen two lower screws in each stand bracket using a 5mm allen wrench.

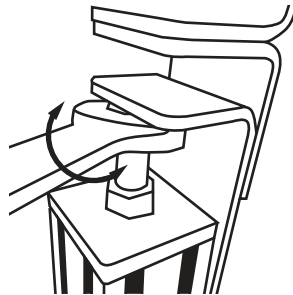

2 Adjust stand height by turning bolt using a 3/4" wrench. Turn clockwise to lower or counter-clockwise to raise. Ensure conveyor is level.

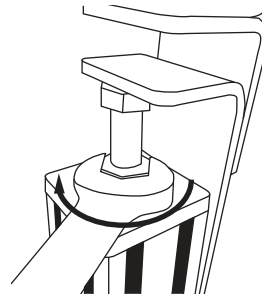

3 Tighten jam nut against top plate of stand.

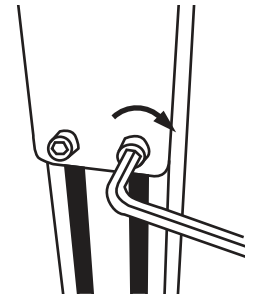

4 Tighten two lower screws in each stand bracket using a 5mm allen wrench.

► Installing Cross Ties

For applications using a single cross tie, the cross tie should be installed between the cross bars of the stands. For applications using two cross ties, the cross ties should be installed between the uprights of the stands. The installation process is the same for each.

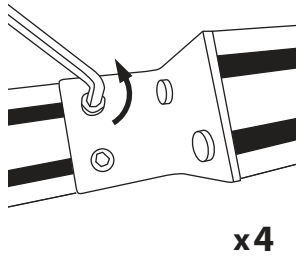

x4

1 Using a 5mm allen wrench, loosen two socket head cap screws in each cross tie adjustment plate.

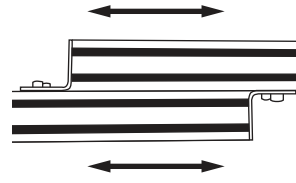

2 Slide adjustable cross tie pieces to fit between stands.

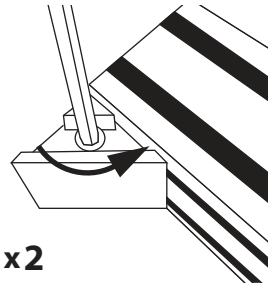

x2

3 Loosen triangular Quick Clamp on each end of cross tie.

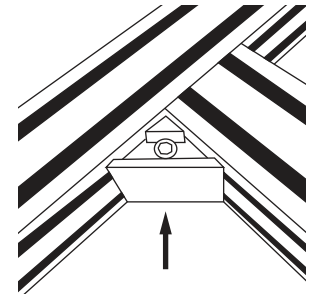

4 Ensuring the socket head cap screw is facing you, slide Quick Clamp into tee slot at desired mounting position.

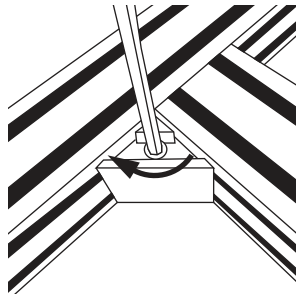

5 Using a 5mm allen wrench, tighten Quick Clamp.

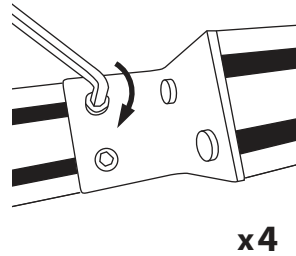

x4

6 Using a 5mm allen wrench, tighten two socket head cap screws in each cross tie adjustment plate.

► Mounting Angle Braces

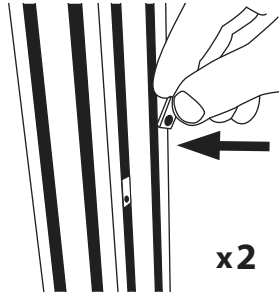

1 Insert drop in nuts into stand leg t-slots. (One per slot)

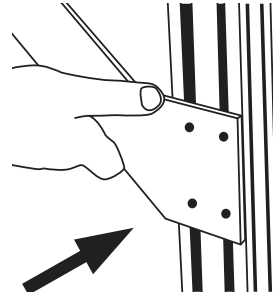

2 Align angle brace over drop in nuts in stand.

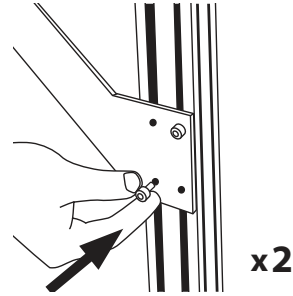

3 Using diagonal holes, insert socket head cap screws through angle brace and into drop in nuts on stand (do not fully tighten).

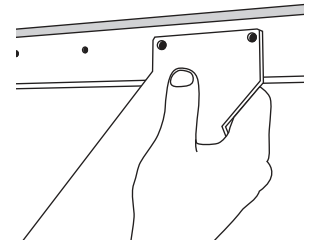

4 Align angle brace to frame holes.

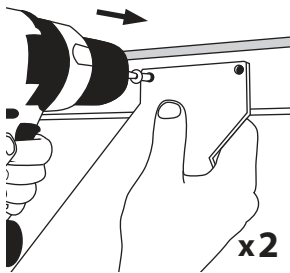

5 Drive in torx screws with a drill.

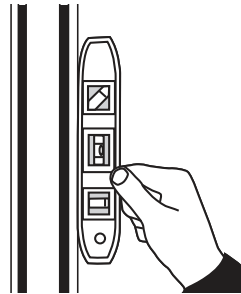

6 Check stand for plumb.



7 Tighten socket head cap screws and repeat process on other side of conveyor.

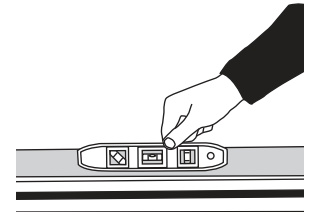

8 Check with bubble level to ensure conveyor is level.

⚠ Injury is possible if the stands are not lagged to the floor, cross ties are not used, or angle braces are not present. Never place a conveyor in operation until all proper mounts are installed and secured.

Warning: Moving conveyors with casters can create dynamic forces that could tip the conveyor. Use caution when moving a conveyor with casters.

Mounting Steel Stands to Conveyor

► Adjust Height of Stand

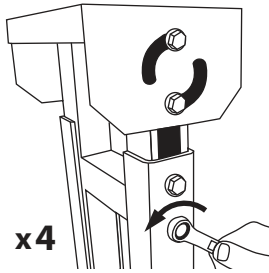

1 Loosen hex head screws.

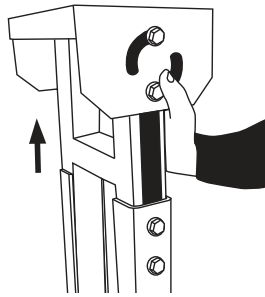

2 Slide H section up or down in channel.

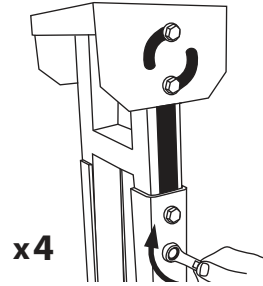

3 Re-tighten screws to secure it in position.

Make adjustments to height of stand before installing conveyor. If it is necessary to use the stand's telescoping adjustment once the conveyor is installed, the conveyor must be supported by some other means, as the stand will not support any weight during the adjustment.

► Attach Conveyor to Base Plate

Follow appropriate instructions in the Mounts section of this manual.

► Measure & Cut Unistrut



1 Measure inside distance between stands.

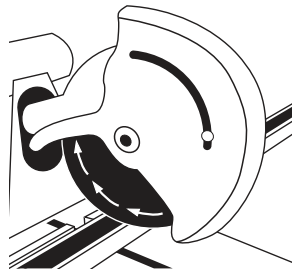

2 Cut unistrut sections to length with appropriate saw.
(Electric chop saw recommended)

► **Installing Steel Cross Ties**

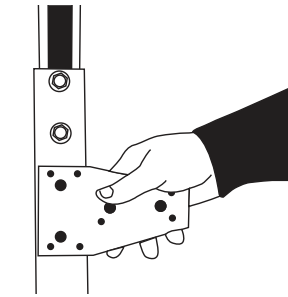

1 Position gusset plate over holes in stand.

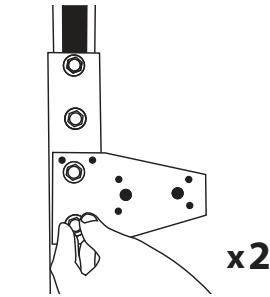

2 Insert 1 ½" hex head screws with flat washers. **x2**

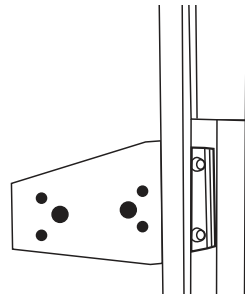

3 Position a double nut clamp inside stand leg.

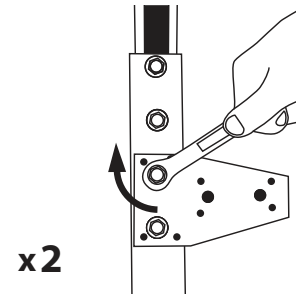

x2
4 Tighten hex head screws into it.

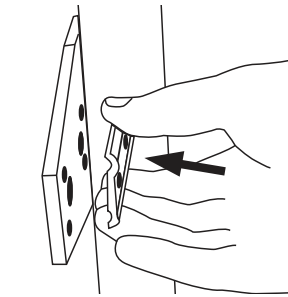

5 Position a double nut clamp on back side of gusset plate.

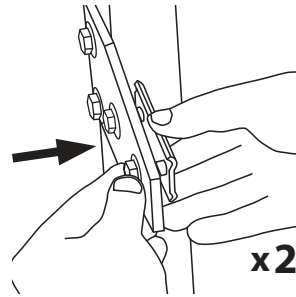

6 Insert hex head screws loosely into holes. **x2**

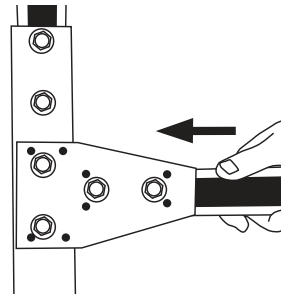

7 Slide unistrut into place.

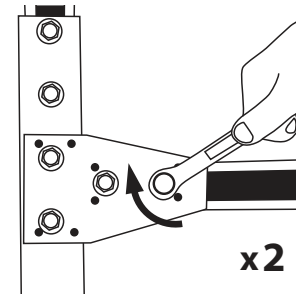

x2
8 Tighten hex head screws.

► **Installing Stabilizers to Leveling Feet for Steel Stands**

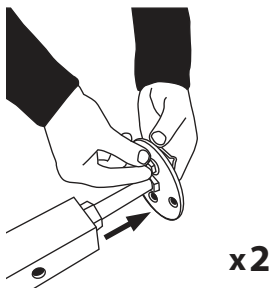

1 Use holes 2" apart. **x2**

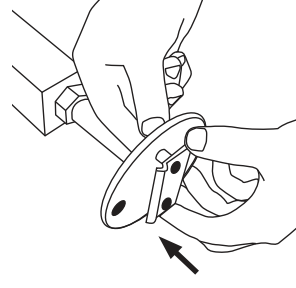

2 Insert 1" hex head screws with 3/8" washers through top of foot and into clamp.

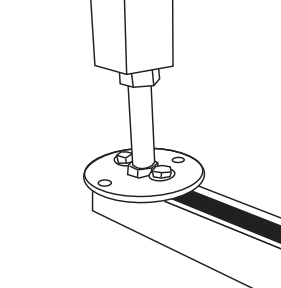

3 Slide double nut clamp into unistrut.

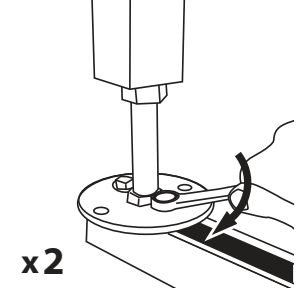

x2
4 Tighten hex screws.

Fine adjustment using the leveling feet is not available once stabilizers are installed.

Mount Installation

Universal Adjustable Mounts / Tee Mounts

► Frame Mounting

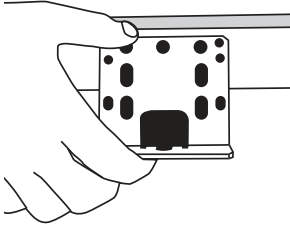

1 Place mount in desired location where there are accessory holes.

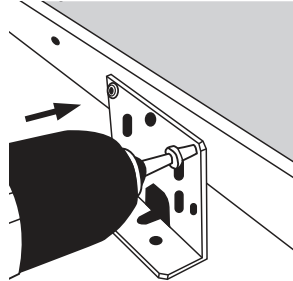

2 Use two thread forming torx head screws and two washers to attach mount to frame.

► Tee Slot Mounting

> The following procedures can also be used for attaching stand brackets and adjustable guide brackets.

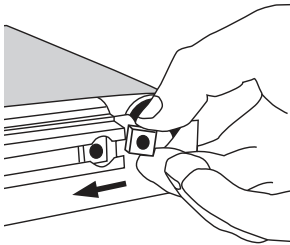

1 Insert square nuts into tee slot.

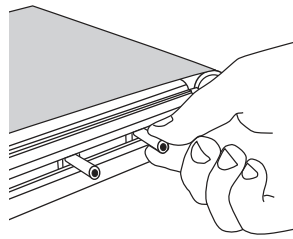

2 Thread 1" set screws into square nuts. (Do not tighten)

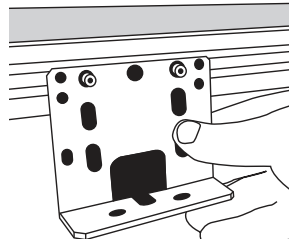

3 Position mount over set screws.

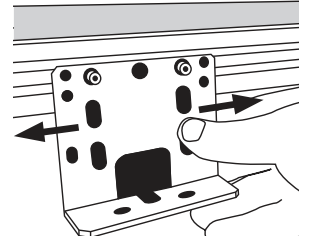

4 Slide mount to desired position on conveyor.

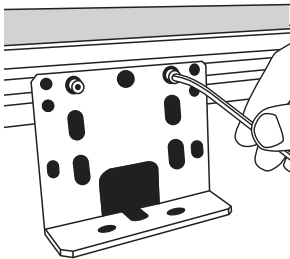

5 Tighten set screws.

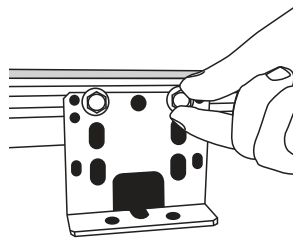

6 Place flat washers onto set screws and thread hex nuts onto them.

► Mounting to Steel Stand

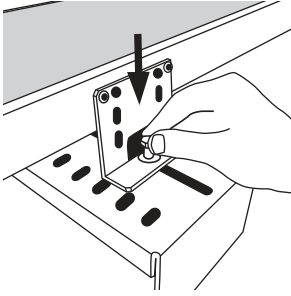

1 Insert $\frac{3}{4}$ " hex screws through a flat washer into slot on mount.

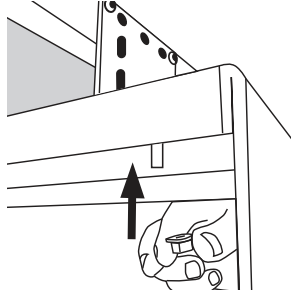

2 Secure mount using a washer and hex nut on underside of stand.

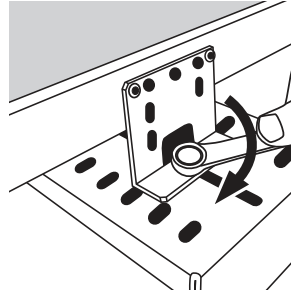

3 Tighten hex head nut.

► Mounting to Multi-Tier Stand

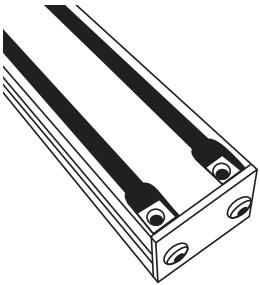

1 Insert a square nut into each channel on top of stand.

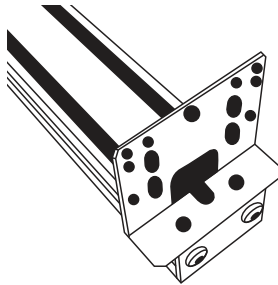

2 Place mount over square nuts in stand.

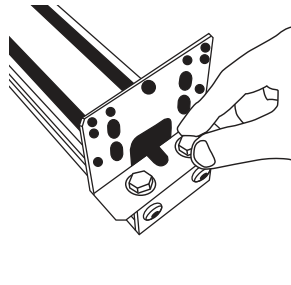

3 Thread $\frac{3}{4}$ " hex head screws through washers into square nuts.

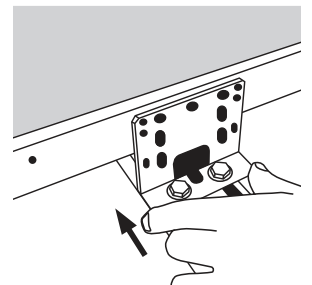

4 Position mount against frame.

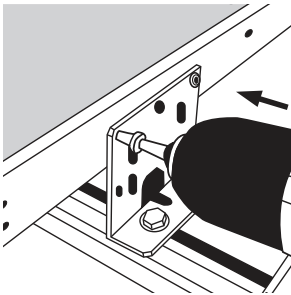

5 Insert thread forming hex head screws through washers and mount into accessory holes on conveyor frame and screw into place.

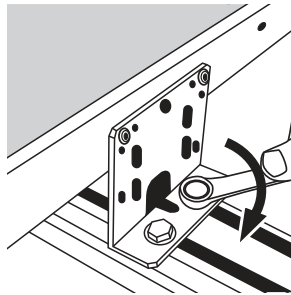

6 Tighten mount to stand.

Bottom Mounts

► Attaching Bottom Mounts to Conveyor

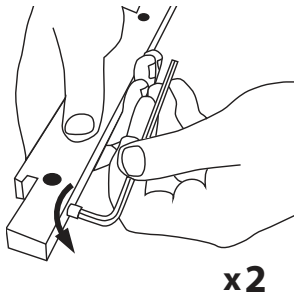

1 Loosen set screws on bottom of mount.

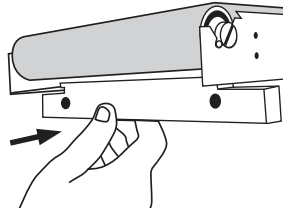

2 Slide bottom mount into conveyor's flange.

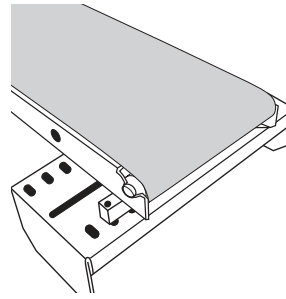

3 Ensure mount is in correct position on mounting surface before tightening set screws.

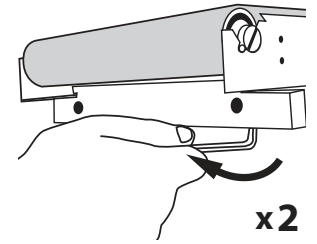

4 Tighten set screws.

► Mounting to Steel Stand

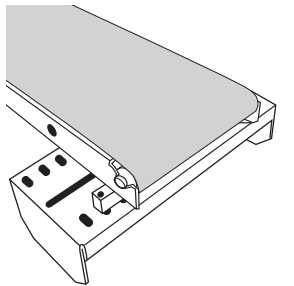

1 Position bottom mount onto stand.

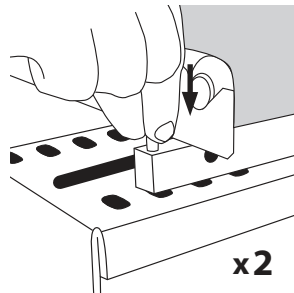

2 Insert socket head cap screws through washers and stand top plate.

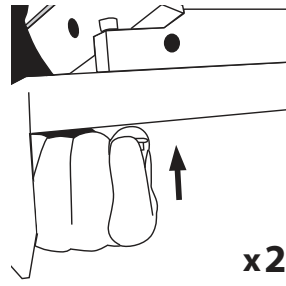

3 Thread hex nuts into screws from underside of top plate.

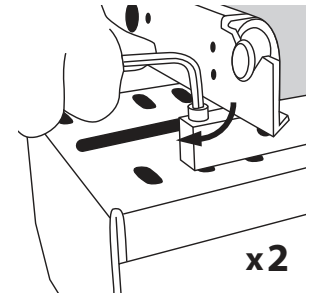

4 Tighten socket head cap screws to secure mount in place.

If Stand is only 2" wider than conveyor, then slots off center of Stand's Top Plate should be used for mounting.

► Face Mounting Bottom Mounts

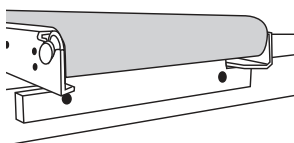

1 Place conveyor with bottom mount against mounting surface.

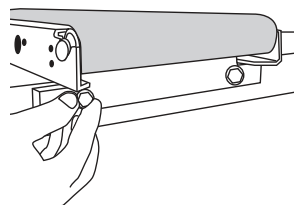

2 Insert 5/16" diameter screws into holes on bottom mount's face. (Screws not included)

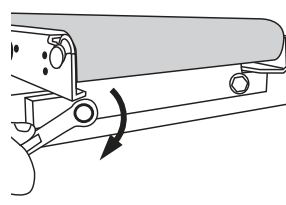

3 Tighten to mounting surface.

Rod Clamp Mounts

► Mounting to Steel Stand

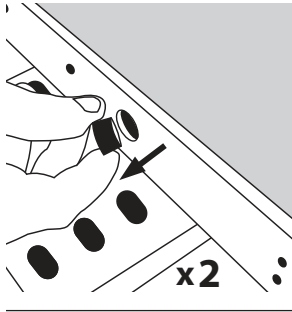

1 Remove frame plug.

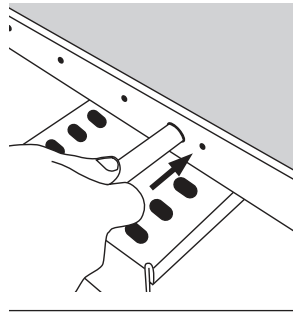

2 Insert rod clamp bar through rod clamp hole. (Ensure counter bore faces away from mounting surface)

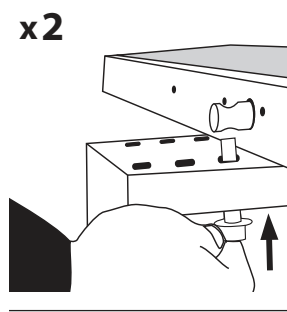

3 Thread screw through a washer and underside of stand's top plate into rod clamp bar to secure.

If Stand is only 2" wider than conveyor, then slots off of center of Stand's Top Plate should be used for mounting.

► Surface Mounting

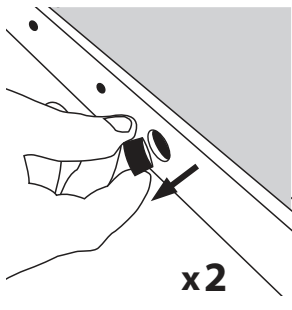

1 Remove frame plug.

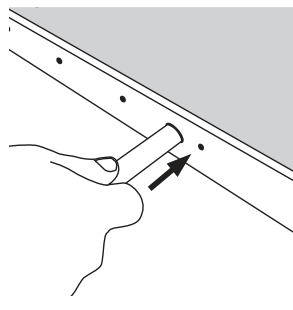

2 Insert rod clamp through rod clamp hole.

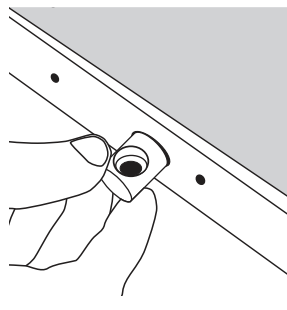

3 Rotate rod clamp mount so counter bore faces away from mounting surface.

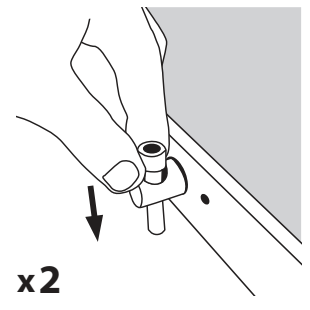

4 Insert a socket head screw through counter bore and into mounting surface.

To protrude past bottom of conveyor frame, screw must be longer than 1".

Side / Guide Installation

Adjustable Guides

► Installing Adjustable Guide Brackets

For guides used with Top Drive Mounting Packages, Guiderail may need to be installed 3" down conveyor, as there will be interference between Guiderail and Drive Mounting Plate; this will cause guides to extend 3" beyond end of conveyor.

> For 1" guides, skip step four. Hex head screws are already installed.

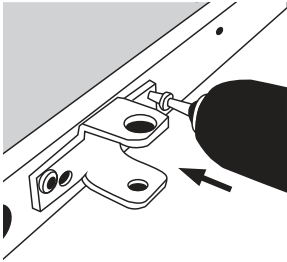

1 Attach guide brackets to conveyor no more than 24" apart, evenly spaced using 7/8" thread forming torx head screws. (Can be attached over stand brackets)

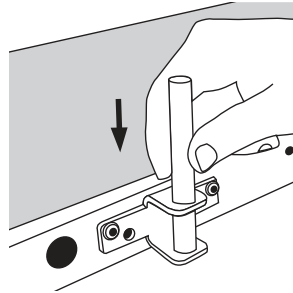

2 Insert vertical rods into each guide bracket.

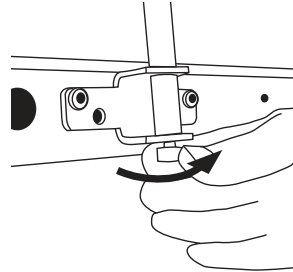

3 Secure each rod with 1/2" hex head screws and 1/4" lock washers.

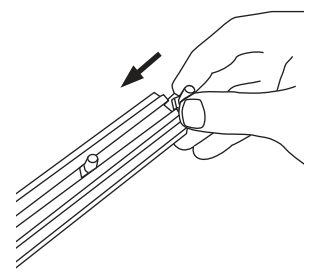

4 Slide 1/4" hex head screws into tee slot of guiderail.

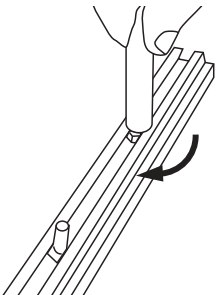

5 Thread adjusting rods onto hex head screws. **Do NOT Tighten.**

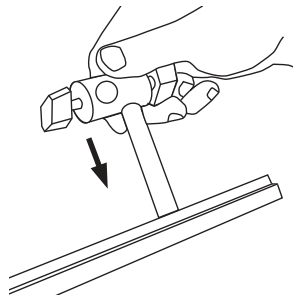

6 Slide a cross block over each adjusting rod.

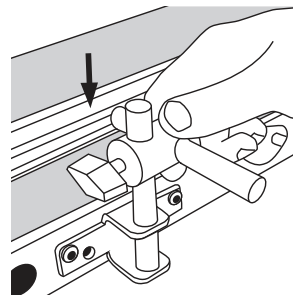

7 Install guiderail and block assembly over vertical rods.

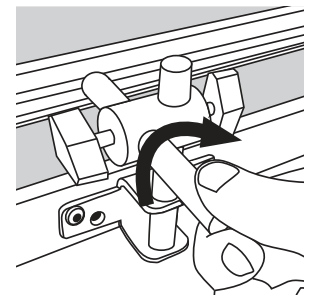

8 Tighten guide bars to guide rail.

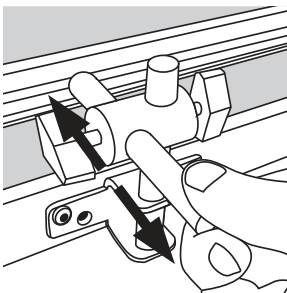

9 Adjust guides to desired width and tighten screw.

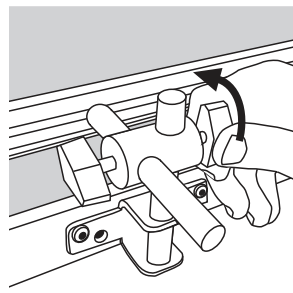

10 Adjust guide to desired height and tighten block assembly to vertical rod. (Guide should **NOT** touch belt)

Fixed Side Rails

► Installing Fixed Side Rails

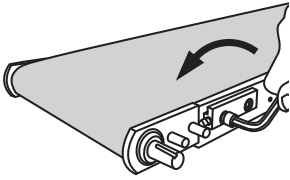

1 Loosen socket head screw in tracking block closest to driver assembly. **Do NOT** loosen second screw.

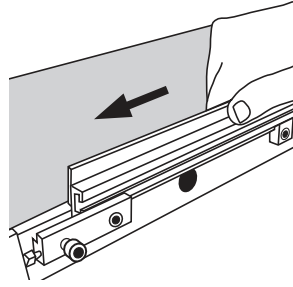

2 Starting at tail end slide side rail through clamps and into tracking block's groove.

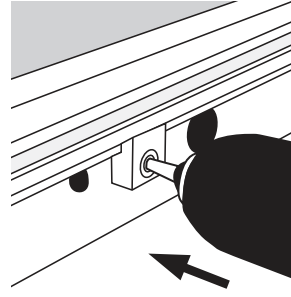

3 Use a screw gun to tighten side rail screws.

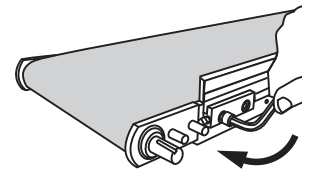

4 Retighten socket head screw in tracking block.

If sides have seals, speed of conveyor should be no faster than 30 feet per minute.

Side seals are designed for use with MAA Standard Urethane Belts.

Drive Packages

The Drive Package will ship separate from the conveyor with the speed reducer attached, and the speed reducer's sprocket already attached to its shaft. For Standard Duty and Pneumatic Drives, the speed reducer and motor will ship installed on the drive mounting package. For Heavy Duty Drives, the motor is always shipped in its own box; the right angle speed reducer will be attached to the drive mounting package.

 QC Conveyors recommends that all wiring be completed by a certified electrician to ensure correct installation. Refer to documentation contained in the motor's box for instructions on electrical connections.

► Side Drive Mounting Package

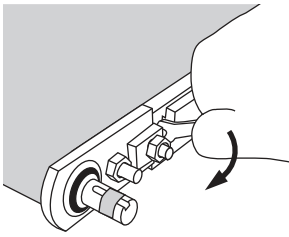

1 Loosen tracking screw from anvil block.

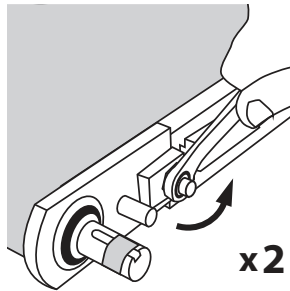

2 Remove two hex nuts and anvil block. Discard anvil block.

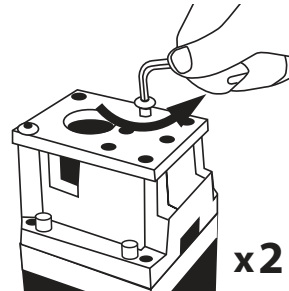

3 Remove screws from drive mounting plate.

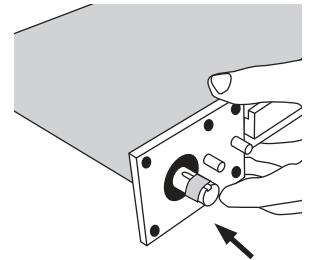

4 Place drive mounting plate over conveyor's spacer block studs.

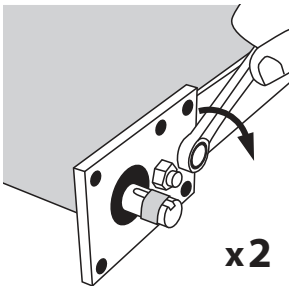

5 Secure plate with two hex nuts.

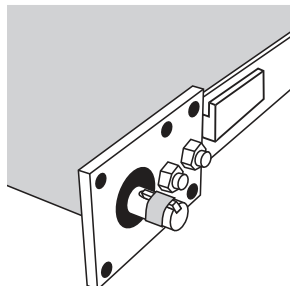

6 Rotate drive pulley so key is in 12 o'clock position.

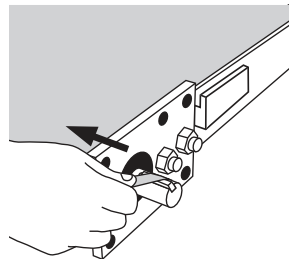

7 Remove tape from key and shaft. **Do NOT** remove key.

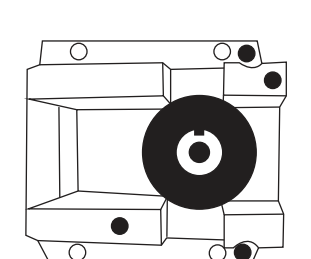

8 Rotate speed reducer keyway to 12 o'clock position.

► Side Drive Mounting Package (continued)

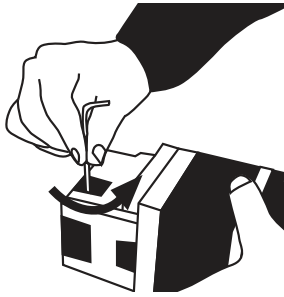

9 Back set screw out of coupler half allowing space for key in key way.



10 Slide speed reducer assembly onto conveyor's shaft and hold in place.

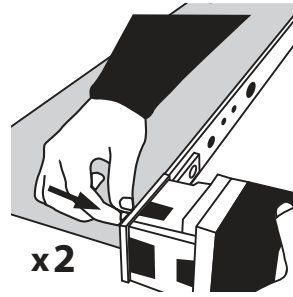

11 While holding, replace and tighten upper button head screw.

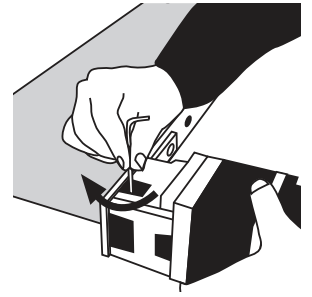

12 Tighten set screw to secure its position on key.

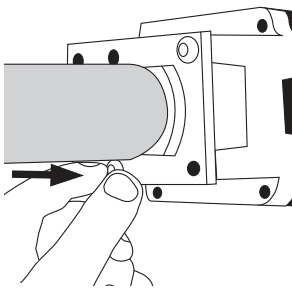

13 Replace lower button head screw.

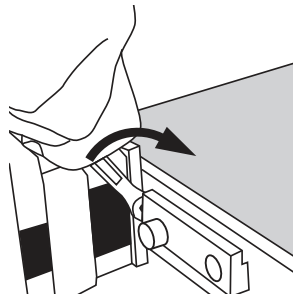

14 Retighten conveyor's tracking screw to drive mounting plate.

► **Top and Bottom Drive Mounting Packages**

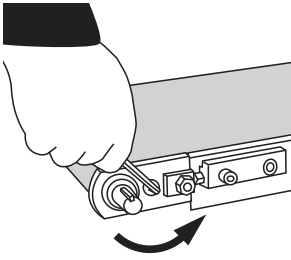

1 Remove flat head screw from bearing plate.

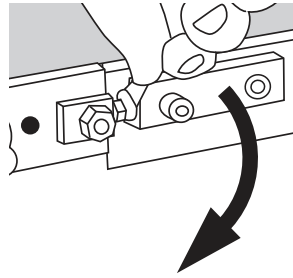

2 Loosen tracking screw from anvil block.

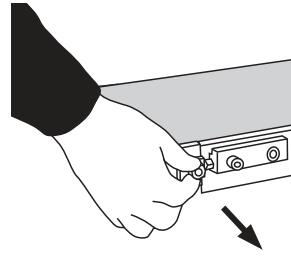

3 Remove hex nut from anvil block.

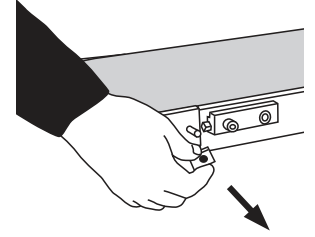

4 Remove anvil block and discard.

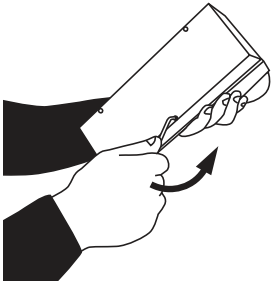

5 Remove plastic guard from mounting package by loosening socket head screws.

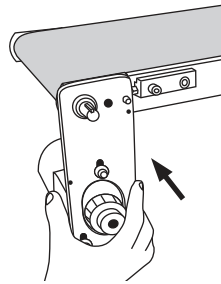

6 Mount drive mounting plate over conveyor shaft and spacer block stud.

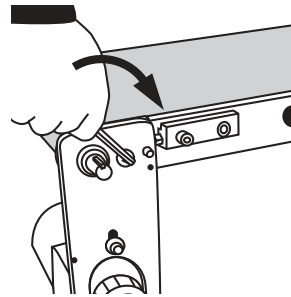

7 Insert and tighten flat head screw in drive mounting plate.

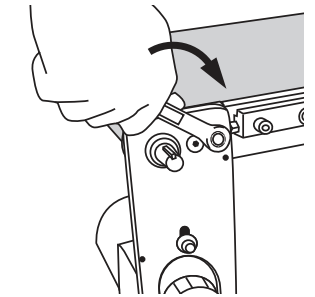

8 Replace and tighten hex nut.

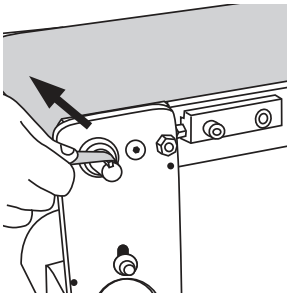

9 Remove tape from conveyor's shaft. Do NOT remove key.

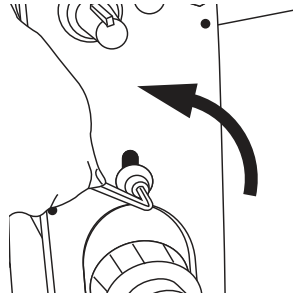

10 Loosen three socket head cap screws.

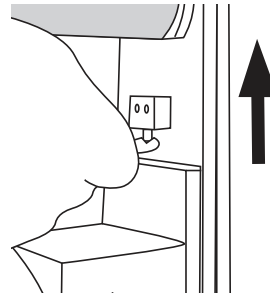

11 Thread jacking screw in to allow sub plate to move toward conveyor.

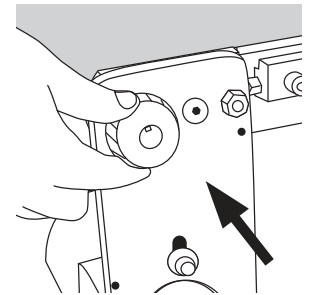

12 Slide top sprocket onto conveyor's shaft key so it is flush with end of shaft.

► **Top and Bottom Drive Mounting Packages (continued)**

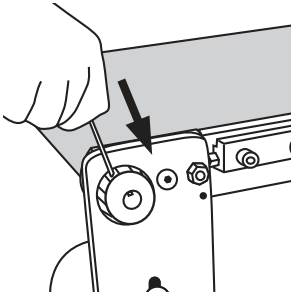

13 Secure sprocket in place by tightening two set screws.

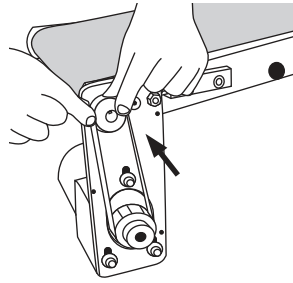

14 Install timing belt or chain.

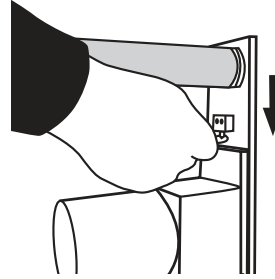

15 Run jacking screw out to create tension on belt/chain. (Approximately 6lbs of force to deflect one span of belt .09")

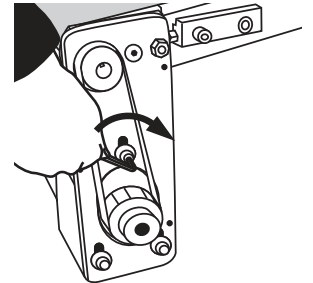

16 Retighten three socket head screws to hold sub plate in position.

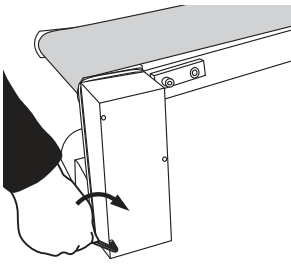

17 Replace plastic guard and secure with three socket head cap screws.

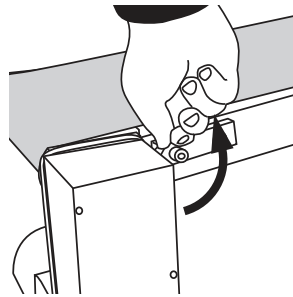

18 Retighten conveyor's tracking screw to drive mounting plate.

Heavy Duty Motors

► Install Vent Plug Into Speed Reducer

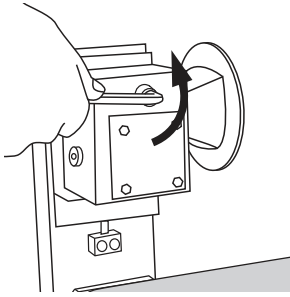

1 Remove pipe plug from top-most port in speed reducer.

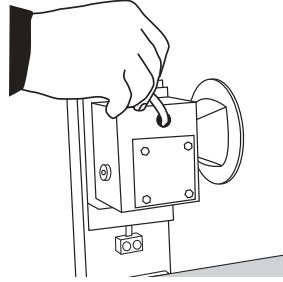

2 Verify that there is oil in reducer.

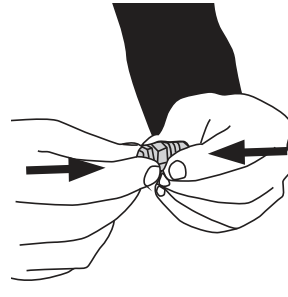

3 Gently thread brass half into plastic half of vent plug.

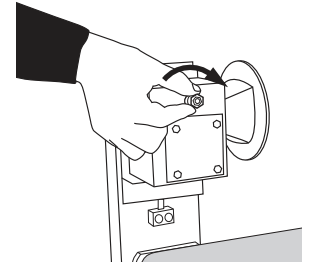

4 Install vent plug in open port. 1/4 turn past hand tight.

For more information, refer to manual provided with speed reducer.

► Install Heavy Duty Motor to Speed Reducer

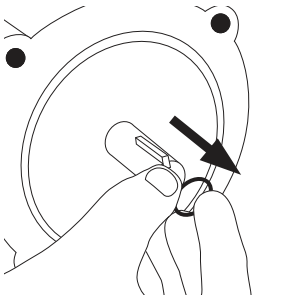

1 Remove key ring.

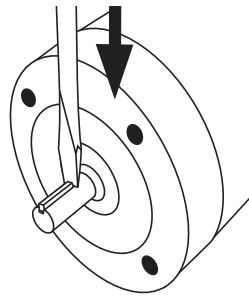

2 Lightly tap area adjacent to key with a flat head screwdriver.

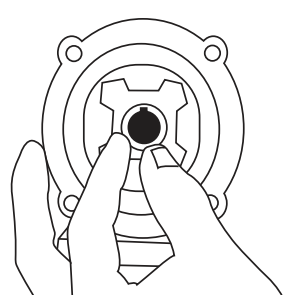

3 Rotate input quill on speed reducer until keyway is in 12 o'clock position.



4 Rotate shaft on motor until key is in 12 o'clock position.

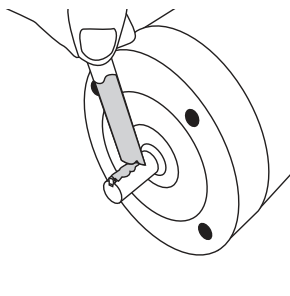

5 Apply a generous amount of anti-seize to input quill and shaft.

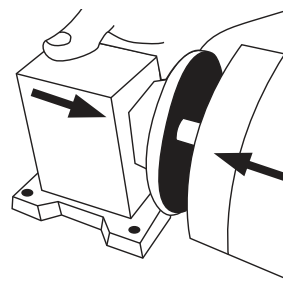

6 Install motor into speed reducer by guiding keyed shaft into place.

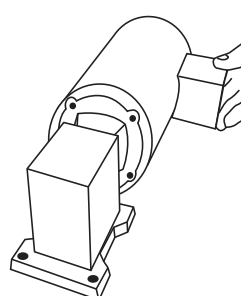

7 Rotate motor until work box is in desired position.

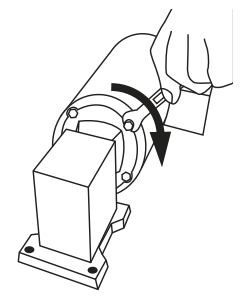

8 Insert and tighten hex head screws to secure motor.

► **Heavy Duty Remote Drive With Shaft**

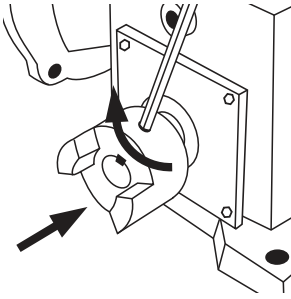

1 Install coupler onto remote drive and tighten set screw to secure.

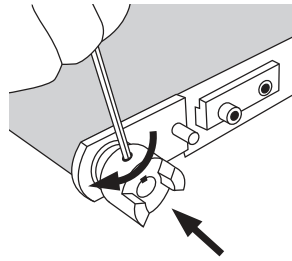

2 Install coupler onto drive pulley and tighten set screw to secure.

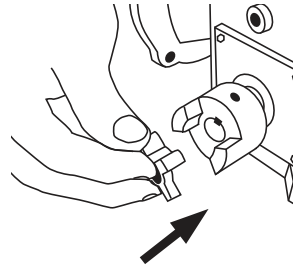

3 Insert spider into coupler half on drive.

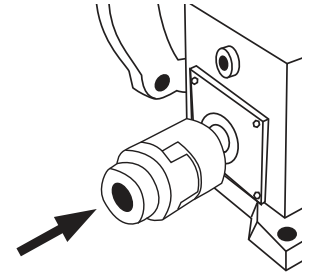

4 Install hex coupler onto motor.

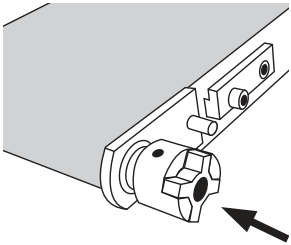

5 Install spider into coupler half on pulley.

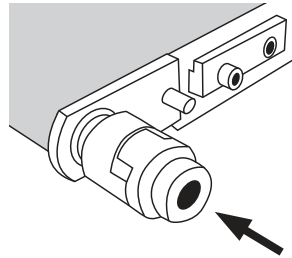

6 Install hex coupler onto drive pulley.

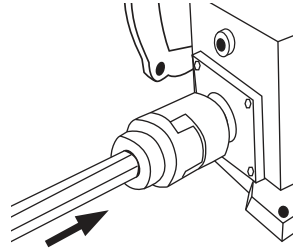

7 Insert hex shaft into hex coupler on motor.

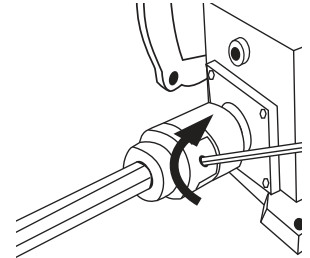

8 Tighten set screw.

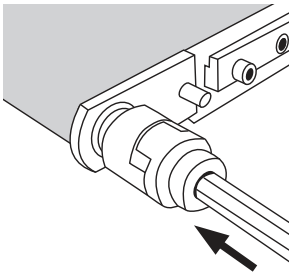

9 Insert shaft into hex coupler on pulley.

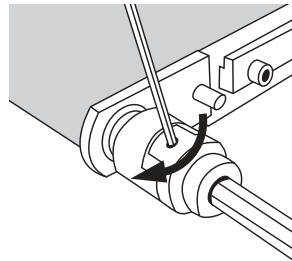

10 Tighten set screw.

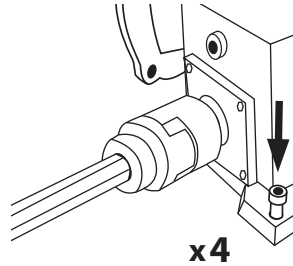

11 Mount drive securely.

► **Heavy Duty Remote Drive Without Shaft**

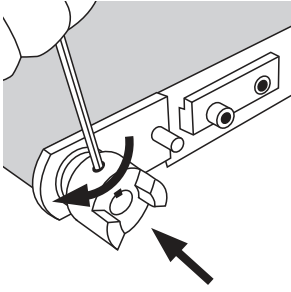

1 Install coupler onto remote drive and tighten set screw.

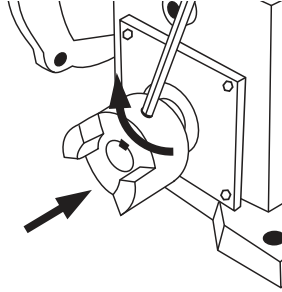

2 Install coupler onto drive pulley and tighten set screw.

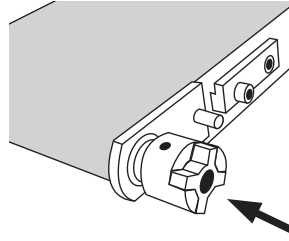

3 Insert spider into coupler half.

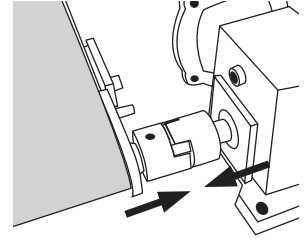

4 Slide couplers together.

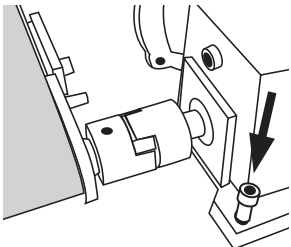

x4

5 Mount drive securely.

Standard Duty and Pneumatic Remote Drives

► Standard Duty and Pneumatic Remote Drive With Shaft

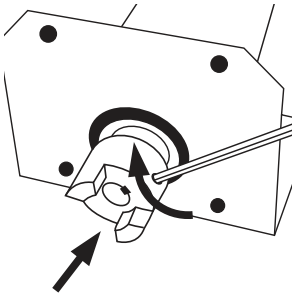

1 Install coupler onto remote drive and tighten set screw to secure.

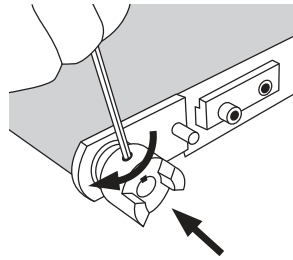

2 Install coupler onto drive pulley and tighten set screw to secure.

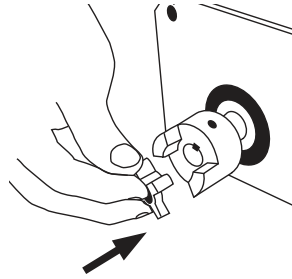

3 Insert spider into coupler half on drive.

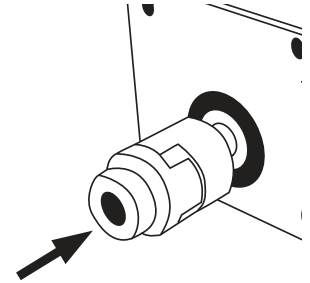

4 Install hex coupler onto motor.

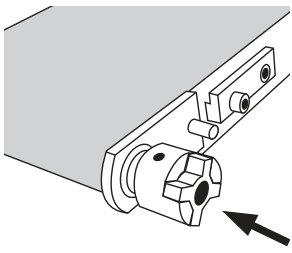

5 Install spider into coupler half on pulley.

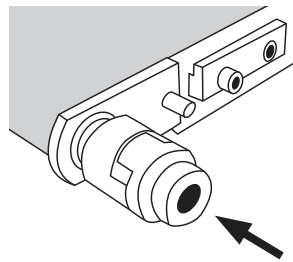

6 Install hex coupler onto drive pulley.

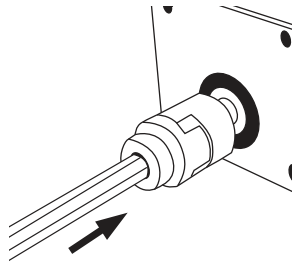

7 Insert hex shaft into hex coupler on motor.

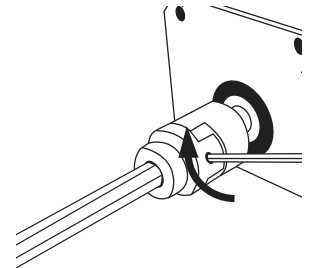

8 Tighten set screw.

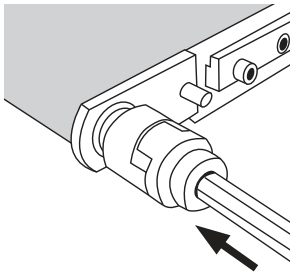

9 Insert shaft into hex coupler on pulley.

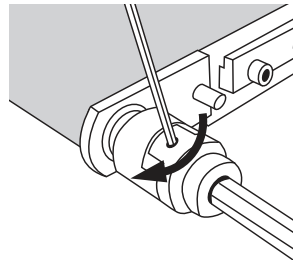

10 Tighten set screw.

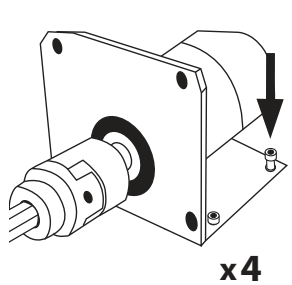

11 Mount drive securely.

► **Standard Duty and Pneumatic Remote Drive Without Shaft**

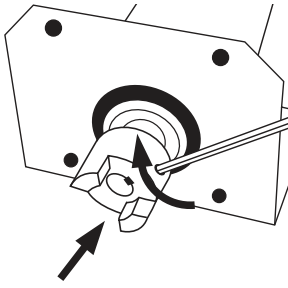

1 Install coupler onto remote drive and tighten set screw.

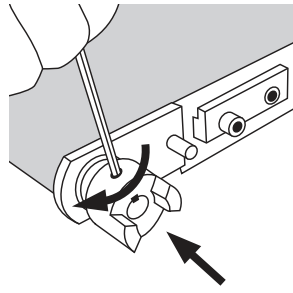

2 Install coupler onto drive pulley and tighten set screw.

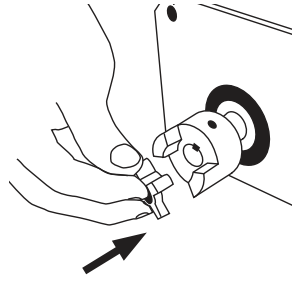

3 Insert spider into coupler half on drive.

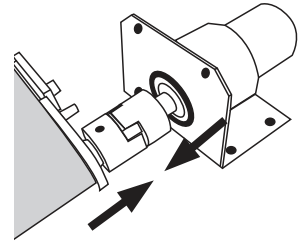

4 Slide couplers together.

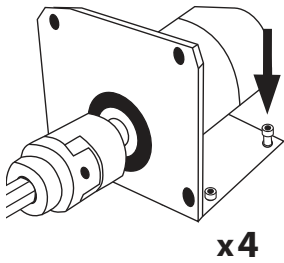

5 Mount drive securely.

Maintenance

Belt Tracking

> For best results, make adjustments to only one side.

► Belt Tracking at Drive End

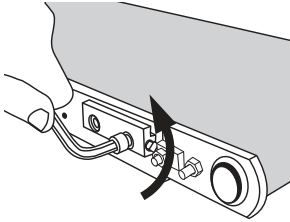

x4

1 Loosen all four driver assembly screws ½ turn.

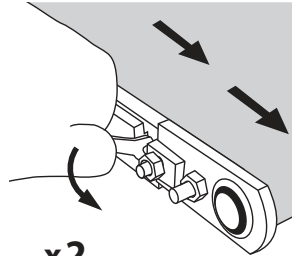

x2

2 With conveyor running, turn tracking screw toward drive pulley on side where belt is riding too close.

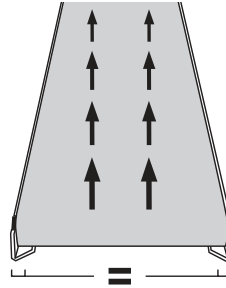

3 Allow several full revolutions to determine if belt is tracked properly. (Repeat Step 2 if necessary)

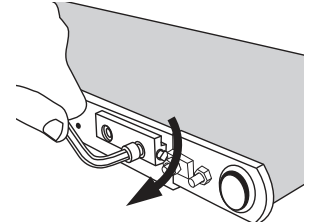

x4

4 Tighten all four driver assembly screws once tracking adjustment is complete.

The Drive End is tracked when the belt can make a full revolution without contacting either bearing plate.

► Belt Tracking at Tail End

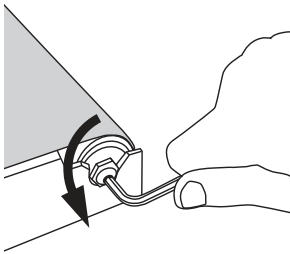

1 Loosen button head socket screw with 5/32" wrench.

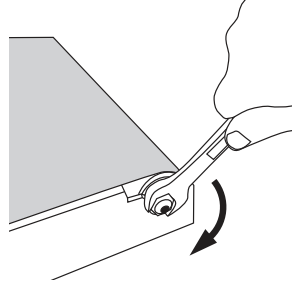

2 Rotate eccentric bearing clockwise to track belt toward eccentric bushing and counter-clockwise to track belt away from eccentric bushing.

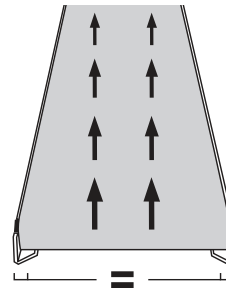

3 Allow several full revolutions to determine if belt is tracked properly. (Repeat Step 2 if necessary)

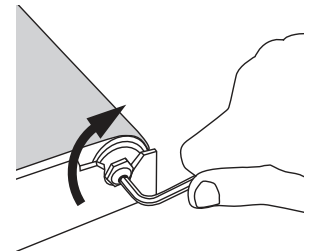

4 Tighten button head socket screw to secure eccentric bushing.

Tail End is tracked when belt can make a full revolution without contacting either side of frame.



To see a video of this process, scan this code on your phone or tablet. You may also visit <http://bit.ly/125tracking>

Belt Change

► Removal of Existing Belt

- > For wide and short conveyors, it may be necessary to remove Bearing Plate and Drive Pulley to remove belt. Instructions can be found in drive pulley replacement sections of this manual.

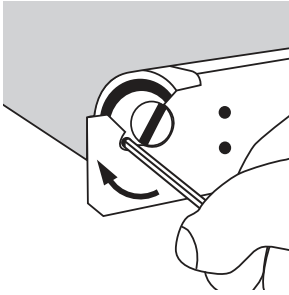

1 Rotate set screw into shaft until it clears frame.

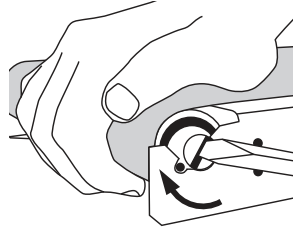

2 Rotate tail assembly 180 degrees to remove belt tension.

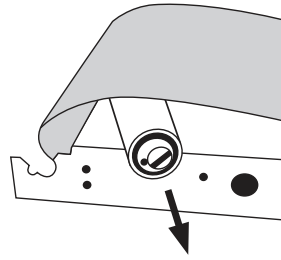

3 Remove tail assembly from frame.

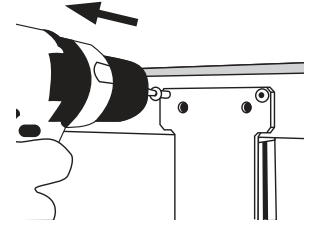

4 Remove torx head screws from stand brackets or mounts on opposite side of drive motor. (If stand brackets are not used, proceed to step 7)

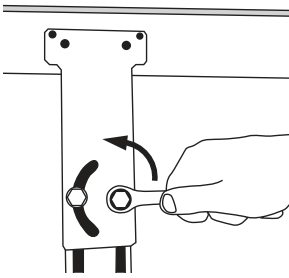

5 Loosen hex head bolts on same side.

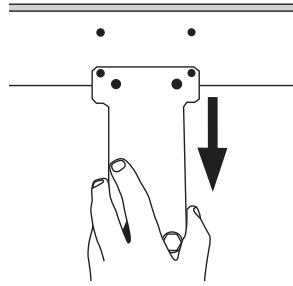

6 Slide mounting brackets down to allow clearance for belt removal.

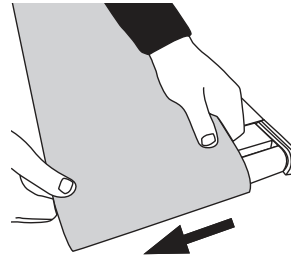

7 Slide belt over drive end making sure to clear drive pulley and bearing plate.



To see a video of this process, scan this code on your phone or tablet. You may also visit <http://bit.ly/125beltchange>

► Installation of New Belt

- > If stand brackets are not used, skip steps 4 and 5.

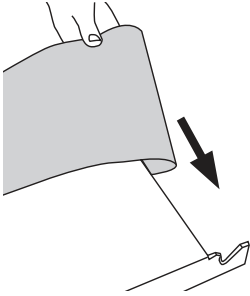

1 Start at tail end and loop belt over frame and into idler cutout.

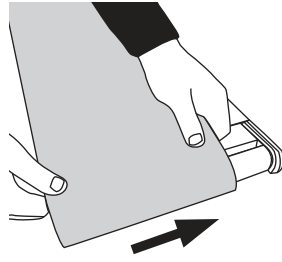

2 Slide belt over drive end.

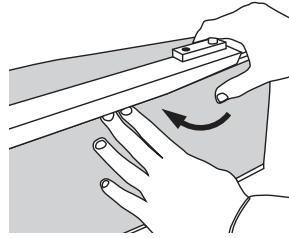

3 Snap belt into flanges on underside of conveyor.

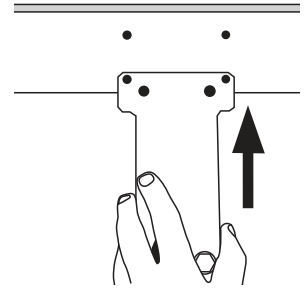

4 Slide mounting bracket up and align with mounting holes.

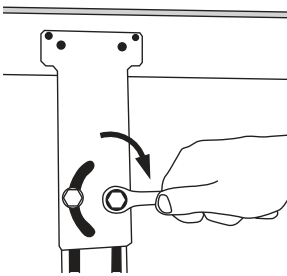

5 Tighten hex head bolts to secure mount to stand.

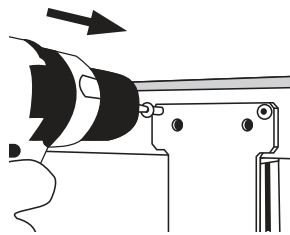

6 Screw torx head screws through mount or stand bracket and into accessory holes on conveyor

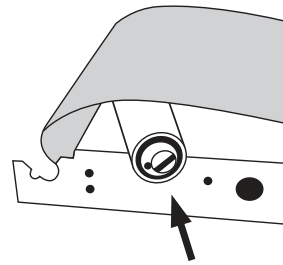

7 Place idler pulley back onto frame under belt.

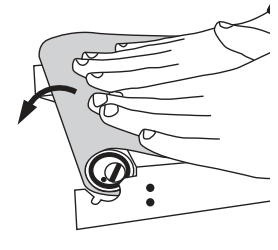

8 Push idler pulley off tail end until it "pops" into position.

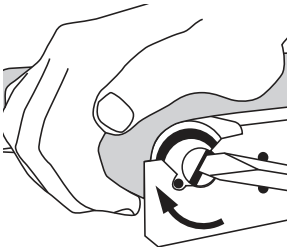

9 Rotate pulley until set screw is visible.

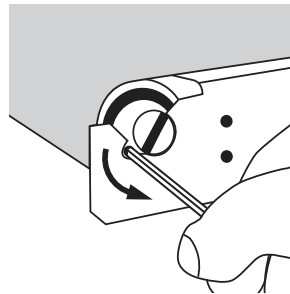

10 Back set screw out to hold pulley in position.

- > If Drive Pulley and Bearing Plate were removed when existing belt was taken off, replace them now. Instructions can be found in drive pulley replacement section of this manual.

Conveyor is now ready to be tracked as instructed in Tracking section of this manual.

► Belt Tension

Belt does not have enough tension when it doesn't move under load or sags below frame.
Belt has too much tension when pulley begins to bow inward towards frame.

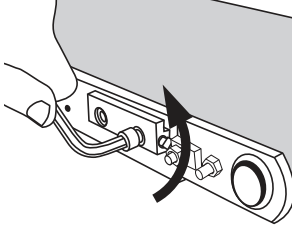

x4

1 Loosen all four driver assembly screws.

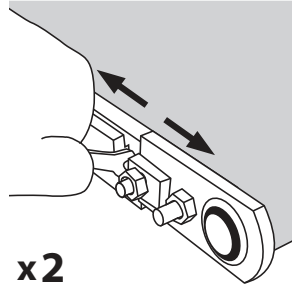

x2

2 Rotate tracking screws in to decrease tension or out to increase tension. (Tracking screw on both sides should be extended same amount.)

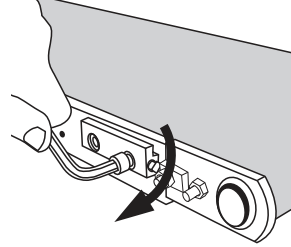

x4

3 Tighten all four driver assembly screws.

If additional belt tension is needed after following these steps and solutions found in the Troubleshooting section of this manual, it is recommended that a new belt be installed.

► Belt Care / Cleaning

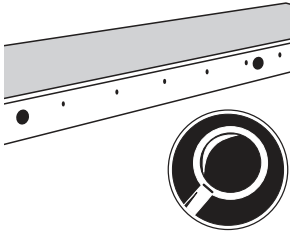

1 Inspect Belt for any fraying or tears and replace if needed.

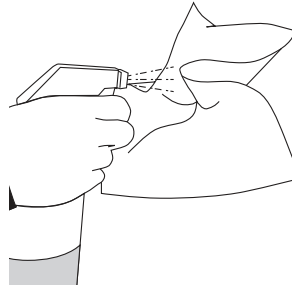

2 Spray cleaning solution on a clean rag.

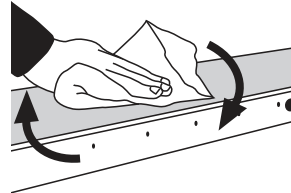

3 Wipe belt with rag.

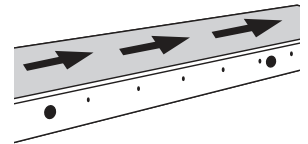

4 Cycle conveyor to reveal opposite side of belt.

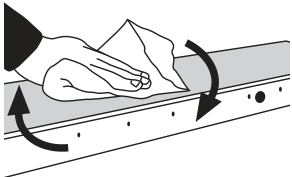

5 Wipe belt with rag.

Bearing Replacement

► Bearing Assembly Replacement

- > Remove drive package. (Follow steps for your drive package in Drive Package section of this manual in reverse order)
- > Release tension at tail end. (Follow steps in Idler Pulley Replacement section of this manual)

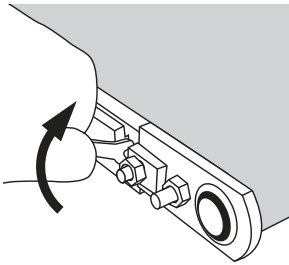

1 Loosen tracking screw from anvil block.

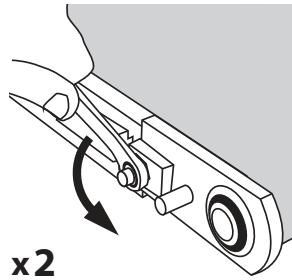

x2
2 Remove two hex nuts and anvil block.

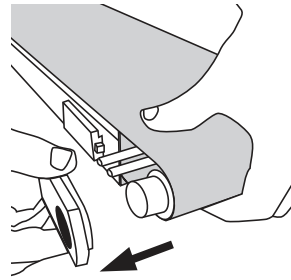

3 Slide old bearing assembly off drive pulley.

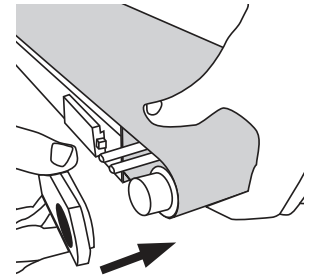

4 Slide new bearing assembly onto drive pulley.

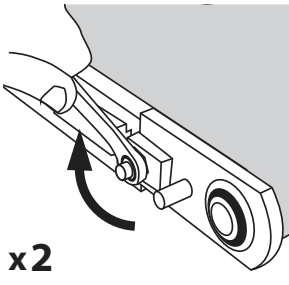

x2
5 Re-install anvil block and two hex nuts.

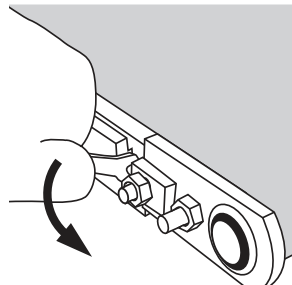

6 Tighten tracking screw into anvil block.

- > Re-tension tail. (Follow steps in Idler Pulley Replacement section of this manual)
- > Re-install Drive package. (Follow steps for your drive package in Drive Package section of this manual)

If tensioning adjustment is needed, refer to belt tensioning section of this manual.

If Tracking adjustment is needed, refer to belt tracking section of this manual.

Pulley Replacement

► Drive Pulley Replacement

- > Remove drive package. (Follow steps for your drive package in Drive Package section of this manual in reverse order)
- > Release tension at tail end. (Follow steps in Idler Pulley Replacement section of this manual)

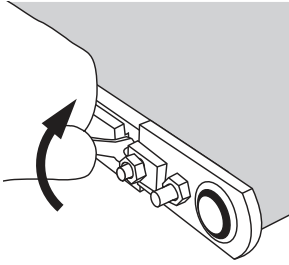

1 Loosen tracking screw from anvil block.

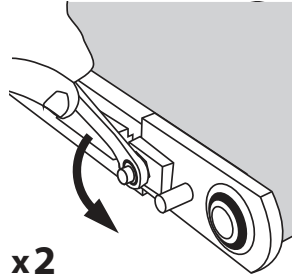

x2
2 Remove two hex nuts and anvil block.

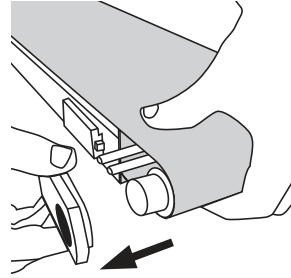

3 Slide old bearing assembly off drive pulley.

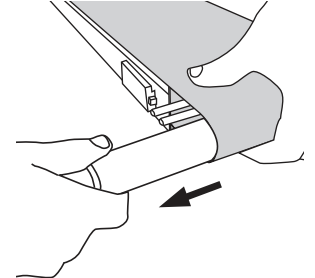

4 Slide old drive pulley out of bearing housing and belt.

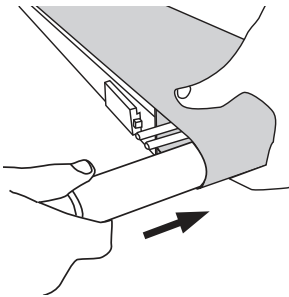

5 Slide new drive pulley into place.

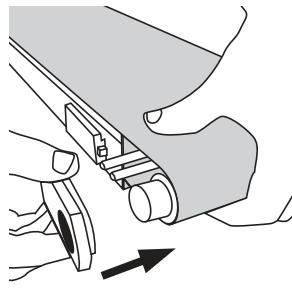

6 Slide bearing assembly onto drive pulley.

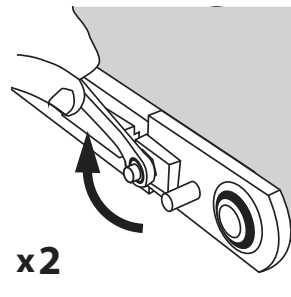

x2
7 Re-install anvil block and two hex nuts.

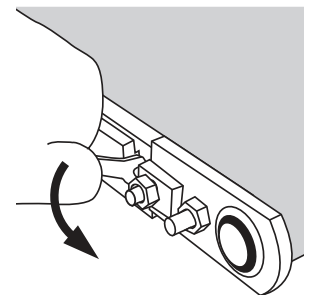

8 Tighten tracking screw against anvil block.

- > Re-tension tail. (Follow steps in Idler Pulley Replacement section of this manual)
- > Re-install Drive package. (Follow steps for your drive package in Drive Package section of this manual)

If tensioning adjustment is needed, refer to belt tensioning section of this manual.

If Tracking adjustment is needed, refer to belt tracking section of this manual.

► Idler Pulley Replacement

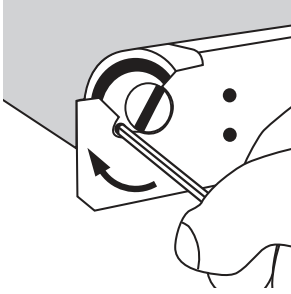

1 Tighten set screw into pulley so it clears frame.

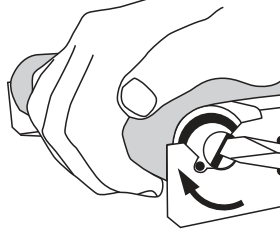

2 Rotate idler pulley 180 degrees to relieve tension.

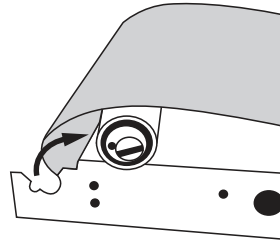

3 Lift idler pulley out of notch in frame.

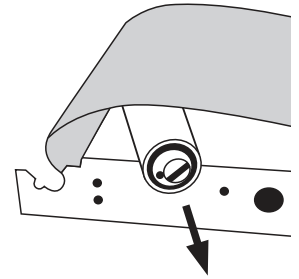

4 Remove idler pulley.

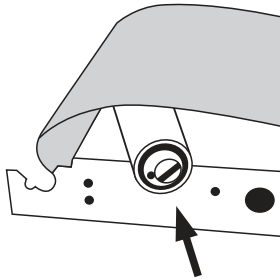

5 Install new idler pulley.

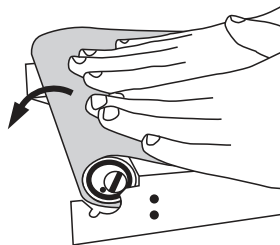

6 Roll idler pulley off tail end until it "pops" into notch in frame.

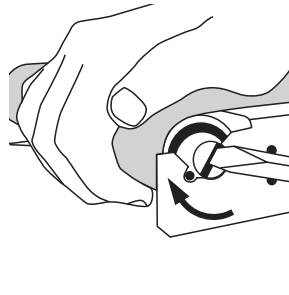

7 Rotate pulley until set screw is visible in slot.

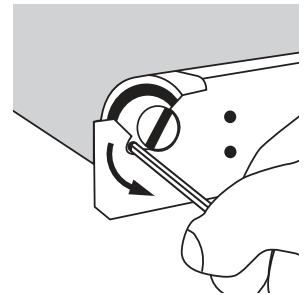

8 Back out set screw to hold pulley in place.

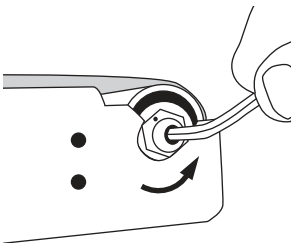

9 Loosen button head screw.

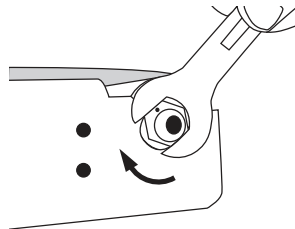

10 Rotate grey eccentric bushing until index mark is in 12 o'clock/neutral position.

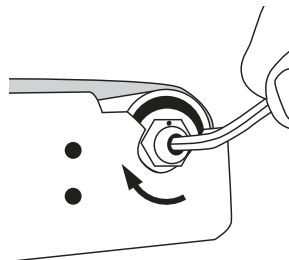

11 Tighten button head screw.

> Retrack belt following steps in Belt Tracking section of this manual.

Speed Reducer

► Changing Speed Reducer Oil

- > Speed Reducers with a "K" in the part number on the nameplate should be filled with Klubersynth UH-1 6-460 (# 096060) oil. Speed Reducers with an "S" in the part number should be filled with Mobile SHC 634 Synthetic oil.

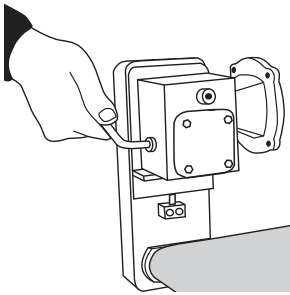

1 Remove lowest plug from speed reducer.

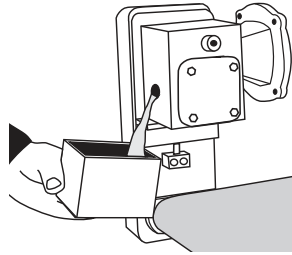

2 Let oil drain until reducer is completely empty.

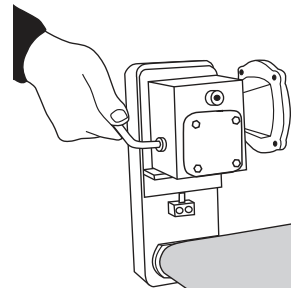

3 Replace plug.

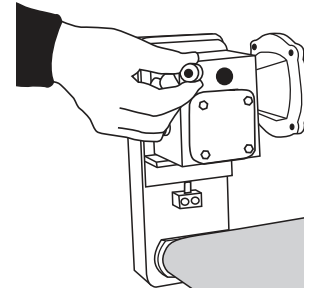

4 Remove upper plug.

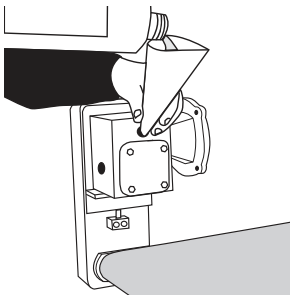

5 Fill speed reducer with 3.3 fluid ounces of oil.

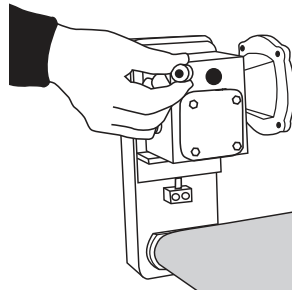

6 Replace plug.

Recommended Spare Parts

► Parts List

Part #	Description
125-0110-WW-E	Sealed Tail Assembly
1E-WW-LLL-MAA	Standard Urethane Belt; your belt code may be different
125-0090-001	RH - Bearing Plate w/Bearing
125-0090-002	LH - Bearing Plate w/Bearing

- > Use the two digit width of the conveyor for "WW".
Use the width and 3-digit length of the conveyor for "LLL".
- > To order parts, please visit qcconveyors.com/serial or call us at (513) 753-6000.

Troubleshooting

Symptom	Possible Cause	Corrective Action
Belt is slipping or stops under load	Demand is more than the conveyor is rated for	Verify conveyor capacity
	Lubrication between drive pulley and belt	Clean bottom of belt and drive pulley
	Eccentric tail shaft not rotated into proper position	Refer to section on tensioning the belt (page 7)
Belt does not move without load	Timing belt or chain not connected	Verify correct installation by referring to drive package section of this manual (page 16)
	Belt not tensioned properly	Refer to section on tensioning the belt (page 7)
Belt will not track at drive end	Accumulation or belt wear	Refer to Belt Tracking section of this manual (page 25)
	Improper tension	Refer to Belt Tension section of this manual (page 33)
Belt will not track at tail end	Irregular product loading or belt wear	Refer to Belt Tracking section of this manual (page 25)
	Improper tension	Refer to Belt Tension section of this manual (page 33)
Belt is brittle, delaminating or is discolored	Belt is being attacked by chemicals or excessive heat	Contact factory to discuss belt application
	Belt life has expired	Replace belt
	Urethane belts can discolor when exposed to UV light	No corrective action
Motor is hot	Motor can run with a skin temperature of 221°F	No corrective action
	Motor is not protected with overload protection and is drawing to much current.	Install overload protection on motor
Speed reducer is getting hot	Speed reducer can run with skin temperature of 225°F	No corrective action
	Speed reducers vent plug was not installed properly	Refer to Vent Plug Installation section of this manual (page 20)
Speed reducer is leaking oil	Speed reducer's life has expired	Replace speed reducer
	Installation was performed incorrectly and input seal was damaged	Replace speed reducer
Bearing noise	Bearings are damaged or failing	Refer to Bearing Replacement section of this manual (page 29)
Belt is traveling reverse of desired direction	Motor or speed reducer not wired properly	Check wiring and correct per wiring instructions
Conveyor belt has prematurely worn out	Correct belt not selected for application	Contact factory to discuss belt application

If you are unable to remedy the problem with these corrective actions, please contact QC Conveyors Customer Service at (513) 753-6000. Failure to correct the problem may lead to abnormal use of the conveyor, thereby voiding the warranty.

Exploded Views / BOMs

► Standard Conveyor

@ - Part Not Sold Separately

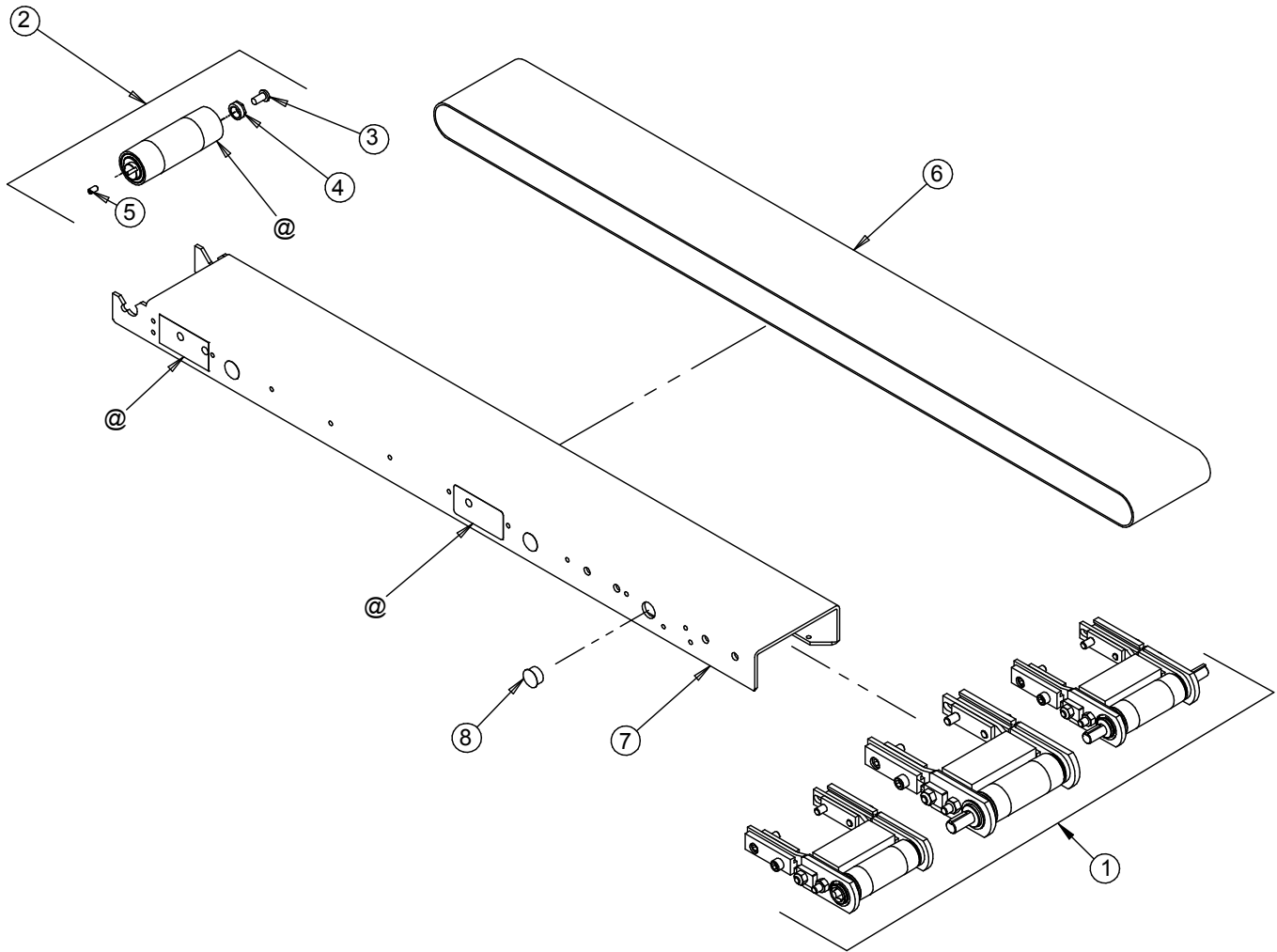

#	Part #	Description
1	125-0099-WW-ST-S-A	ASSY 125 SERIES SINGLE OUTPUT DRIVER
	125-0099-WW-SS-D	ASSY 125 SERIES DUAL OUTPUT DRIVER
	125-0099-WW-HT-H-A	ASSY 125 SERIES HEX INPUT DRIVER
2	125-0110-WW-E	ASSY 125 SERIES TAIL SHAFT
3	125-0071-031	SCREW BUTTON SOCKET HEAD 1/4-28 X 1/2" SS
4	125-0114-00	BUSHING ECCENTRIC FOR TAIL SHAFT
5	125-0070-001	SCREW SOCKET HEAD SET #10-32 X 3/8" SS
6	1E-WW-LLL-MAA	BELT 125 SERIES STANDARD URETHANE
7	125-0086-WW-LLL	FRAME 125 SERIES STANDARD 1.81 HEIGHT
8	125-0078-024	PLUG FRAME

► “D” Driver Assembly

@ - Part Not Sold Separately

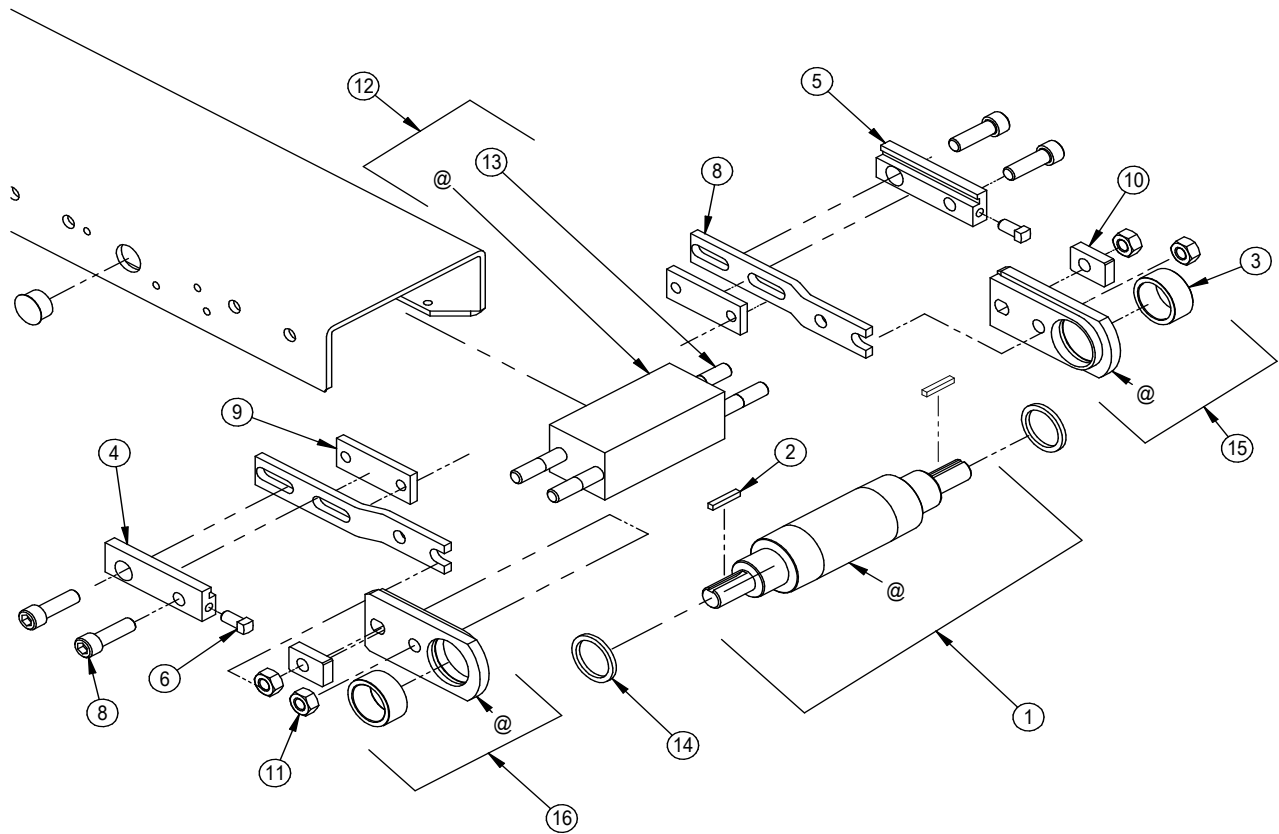

#	Part #	Description
1	125-0140-WW-D	ASSY 125 SERIES "D" DRIVE PULLEY
2	125-0078-018	KEY STD 1/8" SQ X 3/4"
3	SCE148PPOH	BEARING 125 SERIES DRIVE
4	125-0154-TB-LH	BLOCK TRACKING LH 125 SERIES
5	125-0154-TB-RH	BLOCK TRACKING RH 125 SERIES
6	125-0072-025	SCREW SQUARE HEAD SET 1/4-20 X 1/2" ZP
7	125-0074-004	SCREW SOCKET HEAD CAP 5/16-18 X 1" ZP
8	125-0025-00-U	BRACKET DRIVER MOUNTING UNIVERSAL
9	125-0027-00	PLATE DRIVER LOCK
10	125-0023-00	BLOCK ANVIL TRACKING
11	125-0074-014	NUT HEX 5/16-18 ZP
12	125-0019-WW	ASSY SPACER BLOCK WITH STUDS
13	125-0022-00	STUD SPACER BLOCK
14	NT-14LB	WASHER THRUST NYLON
15	125-0090-001	ASSY 125 BEARING PLATE RH
16	125-0090-002	ASSY 125 BEARING PLATE LH

► “S” Driver Assembly

@ - Part Not Sold Separately

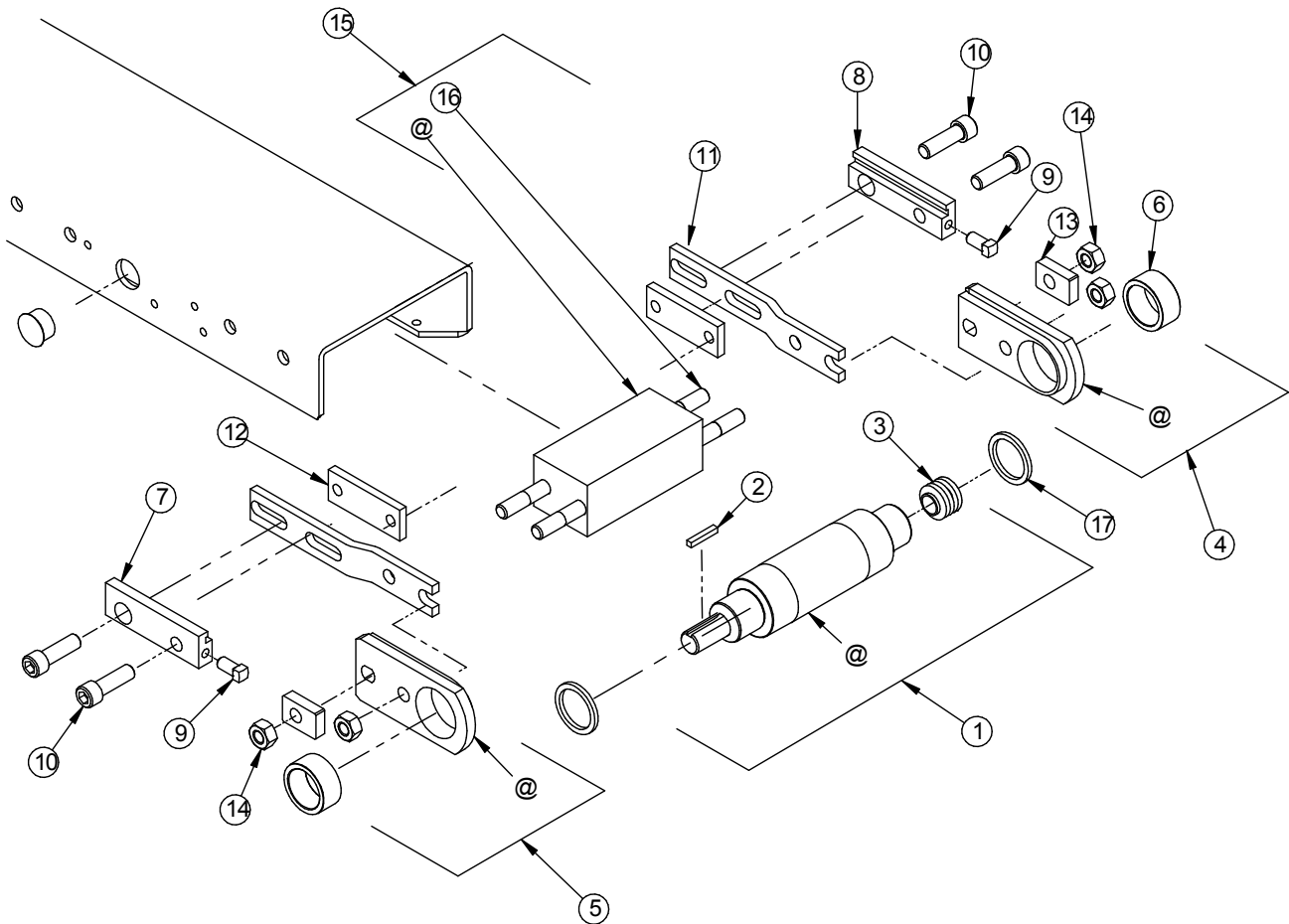

#	Part #	Description
1	125-0140-WW-S	ASSY 125 SERIES "S" DRIVE PULLEY
2	125-0078-018	KEY STD 1/8" SQ X 3/4"
3	125-0078-048	INSERT CAP S PULLEY THRU
4	125-0090-001	ASSY 125 BEARING PLATE RH
5	125-0090-002	ASSY 125 BEARING PLATE LH
6	SCE148PPOH	BEARING 125 SERIES DRIVE
7	125-0154-TB-LH	BLOCK TRACKING LH 125 SERIES
8	125-0154-TB-RH	BLOCK TRACKING RH 125 SERIES
9	125-0072-025	SCREW SQUARE HEAD SET 1/4-20 X 1/2" ZP
10	125-0074-004	SCREW SOCKET HEAD CAP 5/16-18 X 1" ZP
11	125-0025-00-U	BRACKET DRIVER MOUNTING UNIVERSAL
12	125-0027-00	PLATE DRIVE LOCK
13	125-0023-00	BLOCK ANVIL TRACKING
14	125-0074-014	NUT HEX 5/16-18 ZP
15	125-0019-WW	ASSY SPACER BLOCK WITH STUDS
16	125-0022-00	STUD SPACER BLOCK
17	NT14L8	WASHER THRUST NYLON

► “H” Driver Assembly

@ - Part Not Sold Separately

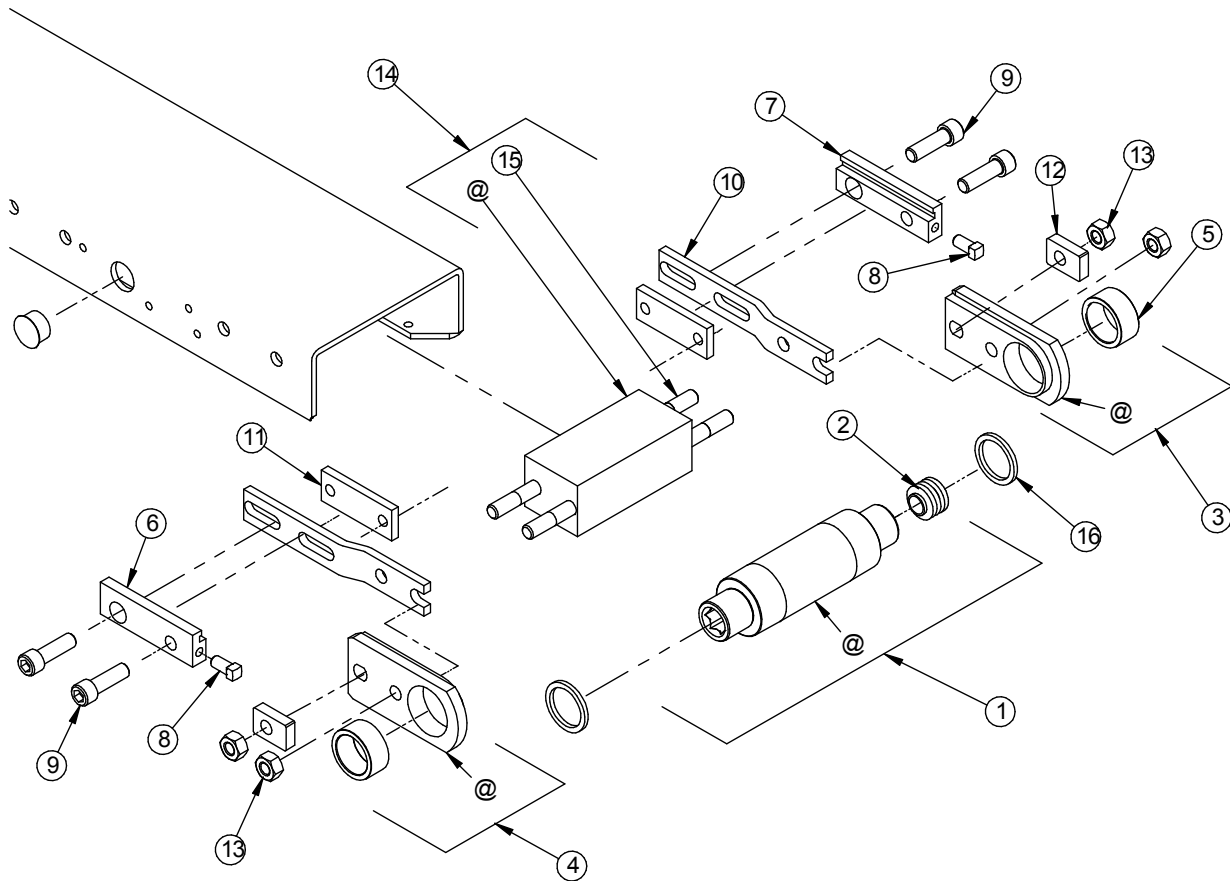

#	Part #	Description
1	125-0140-WW-H	ASSY 125 SERIES "H" DRIVE PULLEY
2	125-0078-048	INSERT CAP S PULLEY THRU
3	125-0090-001	ASSY 125 BEARING PLATE RH
4	125-0090-002	ASSY 125 BEARING PLATE LH
5	SCE148-PPOH	BEARING 125 SERIES DRIVE
6	125-0154-TB-LH	BLOCK TRACKING LH 125 SERIES
7	125-0154-TB-RH	BLOCK TRACKING RH 125 SERIES
8	125-0072-025	SCREW SQUARE HEAD SET 1/4-20 X 1" ZP
9	125-0074-004	SCREW SOCKET HEAD CAP 5/16-18 X 1" ZP
10	125-0025-00-U	BRACKET DRIVER MOUNTING UNIVERSAL
11	125-0027-00	PLATE DRIVER LOCK
12	125-0023-00	BLOCK ANVIL TRACKING
13	125-0074-014	NUT HEX 5/16-18 ZP
14	125-0019-WW	ASSY SPACER BLOCK WITH STUDS
15	125-0022-00	STUD SPACER BLOCK
16	NT14L8	WASHER THRUST NYLON

Warranty Information

QC CONVEYORS warrants that our conveyors are free from defects in materials and workmanship and fit for the ordinary purposes for which such goods are used, under normal installation, use and service for ten (10) years from date of purchase or 21,000 hours* of running use, whichever is sooner. QC CONVEYORS will replace any defective part within the warranty period, without charge, provided:

- > The Purchaser gives QC CONVEYORS prompt written notice of the defect, including the date of purchase and original purchase order number.
- > The Purchaser will then be given a return goods authorization number (RGA#) which must be displayed on all labels and packing slips returned with merchandise. (See RGA section)
- > The Purchaser pays for delivery of the defective part to QC CONVEYORS for inspection and verification of the defect.
- > The Purchaser shall pay any costs of installing the replacement part.

This warranty is limited to the replacement of defective parts. **QC CONVEYORS WILL NOT BE LIABLE FOR ANY DAMAGES CAUSED BY ANY DEFECT IN THIS UNIT.** This warranty shall not apply if any failure of this unit or its parts is caused by unreasonable use, lack of maintenance, improper maintenance and/or repairs, incorrect adjustments, exposure to corrosive or abrasive material, moisture causing damage, or any modification or alteration affecting the operation of the unit which is not authorized by QC CONVEYORS in writing. This warranty shall not apply to the following items that are covered by their manufacturer's warranty, subject to any limitation contained in those warranties.

- > Bearings
- > Motors
- > Reducers
- > Controllers
- > Casters
- > Belts (unless otherwise agreed to in writing)

CAUTION: Any attempt to repair such items may actually void the manufacturer's warranty. Any description of this unit is only to identify it and is not a warranty that the unit fits the description. Any warranties implied by law are limited in duration to the ten (10) year term of this warranty. EXCEPT AS SET FORTH HEREIN, QC CONVEYORS MAKES NO OTHER WARRANTIES, WHETHER EXPRESS, IMPLIED, OR STATUTORY, INCLUDING MERCHANTABILITY FOR FITNESS OR ANY PARTICULAR PURPOSE.

*Warranty is five years/10,500 hours without registration at qcconveyors.com/serial.

► Lost or Damaged Goods

Shipments should be inspected immediately upon receipt for lost or damaged goods. Any loss or damage should be noted on the carriers receipt (or bill of lading) at the time of acceptance. If items are perceived to be lost or damaged after the shipment has been accepted, it becomes more difficult to file a claim with the carrier if the receipt does not indicate such loss or damage. Do not, at any time, request the carrier to return any items or shipment to QC Conveyors without previous authorization from our company for such a return. Please notify QC Conveyors as soon as any loss or damage is discovered and request the department that handles the lost or damaged goods. You will need to know a complete description of all lost or damaged items. If replacement items are needed, a purchase order made out to QC Conveyors will need to be supplied. QC Conveyors will then contact the carrier's local agent and request that an inspection of the items be performed. This is absolutely necessary. Unless an inspection is performed, the carrier will not entertain any claim for loss or damage. After the inspection has been completed, the carrier will notify QC Conveyors. If the carrier takes responsibility for the claim, a credit will be issued to you for the replacement item(s), including freight charges from QC Conveyors, where applicable. If the carrier does not take responsibility for the claim, a representative of QC Conveyors will contact you.

► Return Policy

If, for any reason, an item needs to be returned to QC Conveyors or an in-house order needs to be canceled or revised, the Purchaser is required to adhere to the following series of steps to ensure that the return or cancellation is handled in the proper manner.

- > Promptly call QC Conveyors Customer Service at (513) 753-6000 and request a Returned Goods Authorization. At this time, you will be asked to answer pertinent questions relating to the returned items. We ask that you have the following information ready:
 - (A) Name of distributor (if applicable) through which item(s) were purchased.
 - (B) Name of the Customer and/or end user of the item(s).
 - (C) Any/all purchase order numbers related to the item(s) in question.
 - (D) Phone numbers and names of contacts involved in the return (if it becomes necessary that they be contacted later).
 - (E) Complete part numbers of all items involved in the return.
 - (F) Complete description as to the reason for the return and the actions that need to be taken. (If the item is to be replaced, a new purchase order number must be supplied by the Purchaser along with complete shipping and billing instructions. These replacements will be treated as separate orders by QC Conveyors and evaluated for possible credit only after returned items are received and evaluated.

- > After the call is made to QC Conveyors, we will process your RGA and you will be emailed the RGA number to use for returning the item(s). RGA numbers will not be given verbally over the phone.
- > Upon receipt of your RGA, you are required to return the item(s) within 30 days of receipt of authorization. After 30 days, the Return Authorization will be void if item(s) are not received by QC Conveyors. All shipping charges and freight insurance charges of returned goods will be the responsibility of the Purchaser.
- > The RGA number must be clearly marked on the outside of all packages. It must also be on any paperwork, packing slips, or delivery receipts. If there is no RGA number visible on the package, the package may be refused and sent back at the Purchaser's expense.
- > After receipt of returned goods, QC Conveyors will evaluate the item(s) for credit and take the appropriate action. Standard items that are returned in new, resalable condition will be credited for the amount of the purchase less 20%. Full credit will only be issued on items that are considered to be defective at the time of shipment from QC Conveyors and are evaluated to be under warranty. Please allow 30 days for credits to be issued.

► Order Cancellation / Revision Policy

If it becomes necessary to cancel or revise an order prior to the order being shipped, QC Conveyors reserves the right to evaluate each order that is to be canceled or revised and determine if any charges are applicable. A 20% restocking charge will apply if an order is assembled and ready to ship prior to its cancellation or revision and the order is totally comprised of standard stock items. If the order contains other than stock items, an evaluation will be made based on the status of the order. Additional charges will be included with the 20% restocking charge if any of the following conditions are met:

- (A) The order contains any items that are considered to be non-stock items and these items have already been produced by QC Conveyors or one of its suppliers.
- (B) The order contains any items that require special handling or assembly and these processes have been completed.
- (C) The Customer has specified that they will pick-up an order from QC Conveyors' facility by a predetermined time and that time frame has expired. In this case, QC Conveyors will make an attempt to notify the Customer. If this cannot be accomplished in a reasonable time, the order will be disassembled and the Customer will be charged a restocking fee and any additional charges based on the orders contents as explained herein.

»» qcconveyors.com/serial

Manuals, Videos, Replacement Parts

» Register today to double your warranty to 10 Years

QC Conveyors come standard with a 5 Year manufacturer's warranty, but if you register online we'll double that to 10 Years, giving you the longest warranty in the conveyor industry.



Register today at qcconveyors.com/serial!

While You're There, You'll Have Access to

- » All the installation and maintenance manuals for your product
- » Product-specific videos to guide you through routine maintenance tasks
- » A complete list of replacement parts along with the original bill of materials and exploded views to help you find exactly the right part
- » Easy replacement part quoting



Registration also entitles you to all the benefits of our Conveyor Configurator, where you can configure and quote conveyor systems with help from our engineering-based configuration tools to ensure your conveyor and components will work together perfectly in your application.

Notes:

Notes:

Service Record

Date	Service Performed

▶ **Serial Number**

▶ **Date of Installation**

Service Record

Date	Service Performed

▶ **Serial Number**

▶ **Date of Installation**
