

DODGE® STEEL-HOUSED IMPERIAL HD & S-2000 HD



BEARINGS

Heavy-Duty DODGE Quality for Tough Applications

DODGE steel-housed IMPERIAL HD & S-2000 HD mounted roller bearings combine proven IMPERIAL and S-2000 bearing technology with steel housings specifically designed for harsh applications.

In addition to the wide choice of steel housing configurations, the high capacity, double row spherical bearing elements are protected by exclusive sealing systems for maximum shielding. Optional end caps offer additional protection from contaminants. The sealed inserts can be quickly replaced on-site, saving valuable time and effort compared to bearings which must be rebuilt.

Choose between the exclusive time & shaft saving IMPERIAL adapter mounting system or the economical S-2000 set screw mount. The DODGE steel-housed HD line offers versatility and quality synonymous with the most recognized brand in mounted bearings.

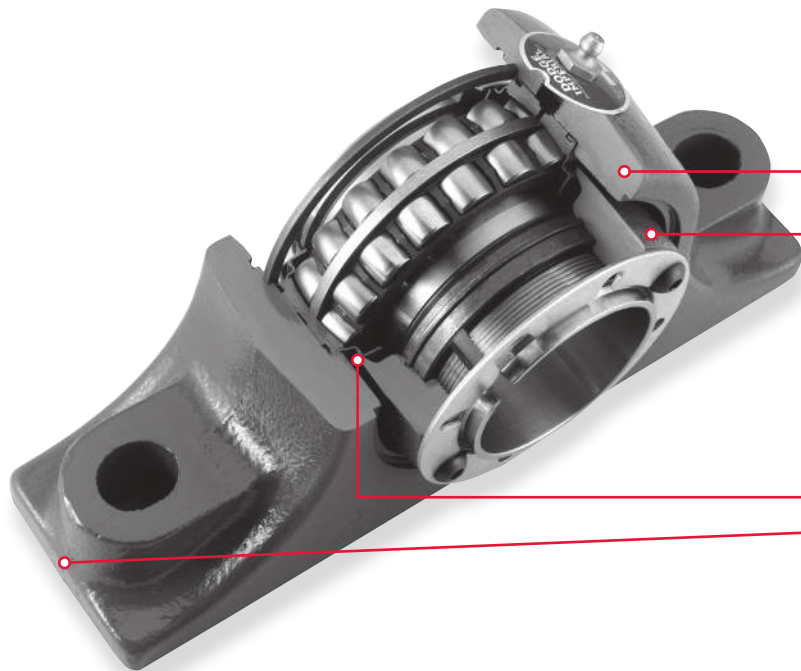
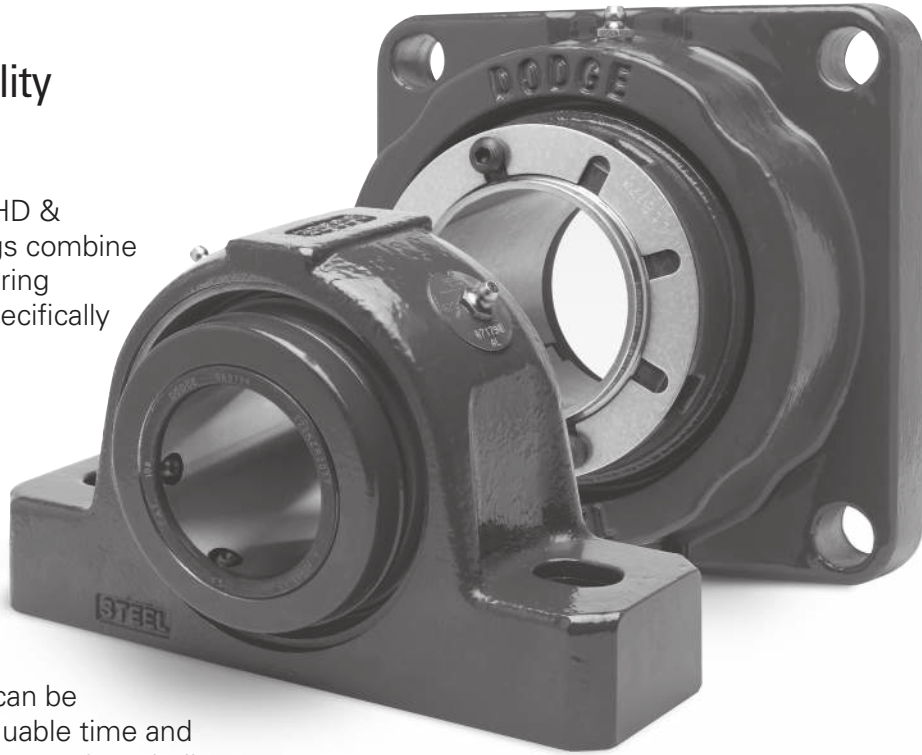

GENERAL FEATURES:

Cast steel housings include a lifetime guarantee against breakage

Single piece inserts

Proven DODGE sealing systems, triple lip & labyrinth

Machined feet assure interchangeability

BALDOR
A MEMBER OF THE ABB GROUP

DODGE IMPERIAL HD

STANDARD FEATURES AND BENEFITS

- Patented adapter mounting system
- Multiple steel housing designs
- Replaceable inserts
- Choice of triple lip or labyrinth seals
- Expansion/non-expansion convertible
- Housings designed for harshest applications
- Easier to install/remove than conventional adapters



Patented Bearing Inserts

- Adapter sleeve improves concentricity, reducing inherent vibration
- Steel cage provides high temperature capabilities and precision roller guidance
- Tapered seal land maintains full contact when misaligned
- Corrosion resistant flinger blocks contaminants
- Clearance setting accomplished by turning nut a specific distance past the zero point

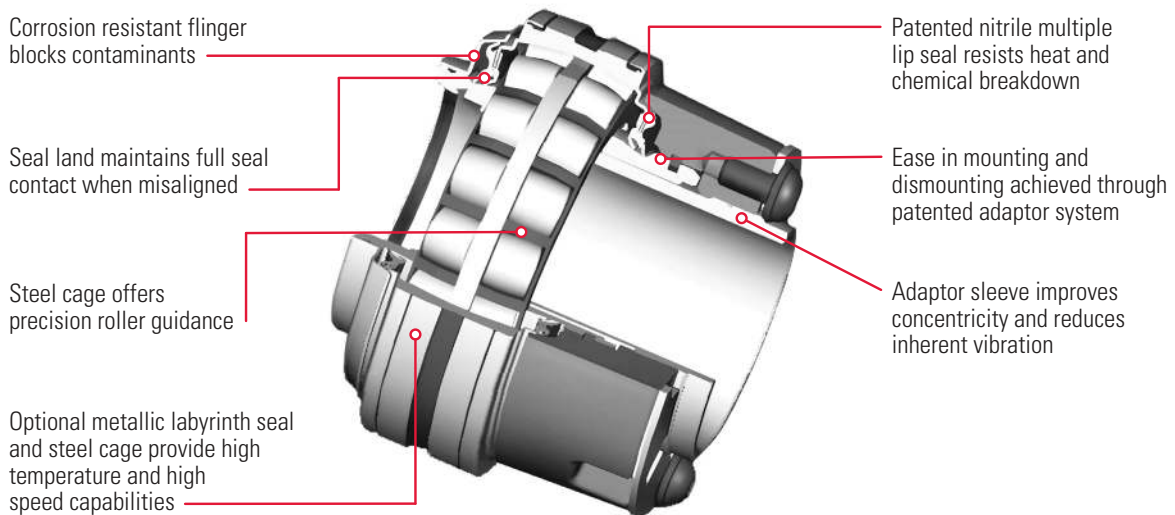

IMPERIAL HD & S-2000 HD: EXPANSION VS. NON-EXPANSION

- Field convertible
- Single snap ring
- Setting determined by position of ring in housing bore
- Part numbers available for ordering either configuration

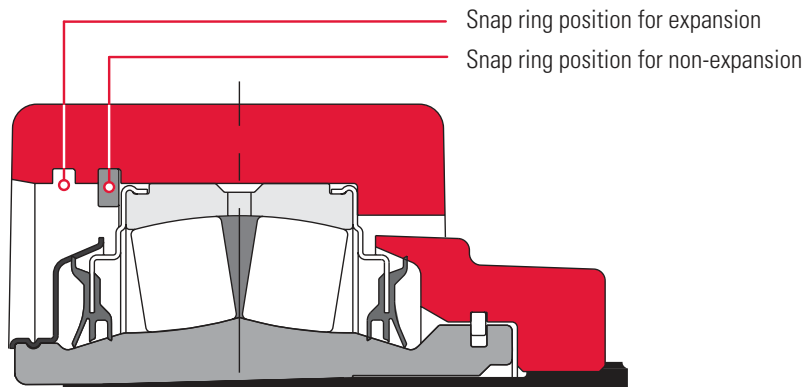

DODGE S-2000 HD

STANDARD FEATURES AND BENEFITS

- Setscrew shaft mount
- Multiple steel housing designs
- Replaceable inserts
- Choice of triple lip or labyrinth seals
- Expansion/non-expansion convertible
- Housings designed for harshest applications
- Quick and simple installation
- Easy insert replacement
- Economical

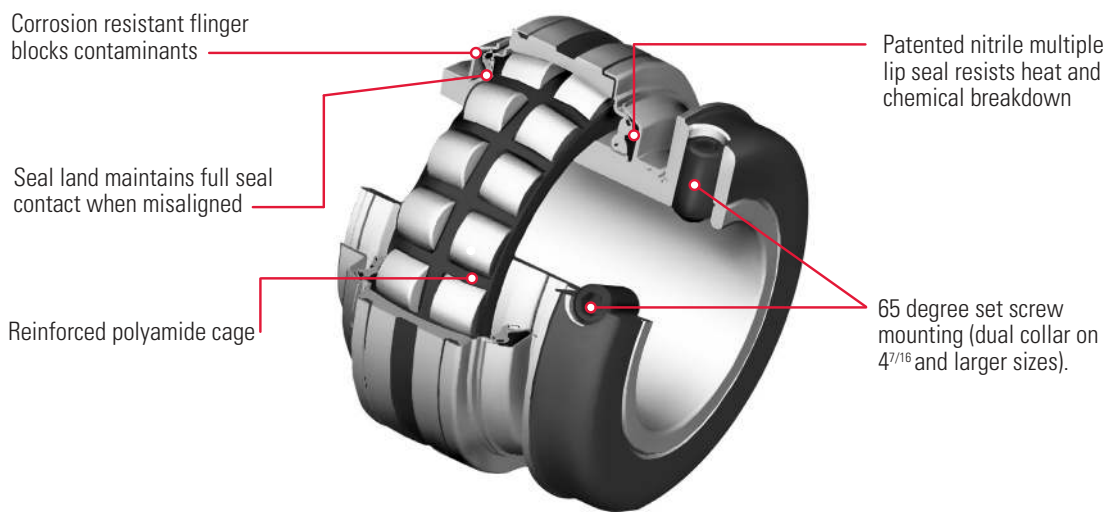







ACCESSORIES

END CAP KITS FIT IMPERIAL AND S-2000

- Powder coated end caps
- Shaft through: Open
- Shaft end: Closed



	Description	IMPERIAL	S-2000
	Pillow Blocks, 2 bolt	1 1/8 – 4"	1 3/8 – 3/15/16"
	Pillow Blocks, 4 bolt	2 3/8 – 5"	2 7/16 – 4 15/16"
	Flange, 4 bolt	2 3/8 – 4"	1 3/8 – 3 15/16"
	Flange, 4 bolt, E-dimensions	1 3/8 – 4 1/2"	Made to Order Consult Baldor•Dodge for availability
	Flange, piloted	1 1/8 – 5"	Made to Order Consult Baldor•Dodge for availability
	Edger Flange, piloted	1 7/16 – 4 1/2"	Made to Order Consult Baldor•Dodge for availability
	Sealed Inserts	1 1/8 – 5"	1 3/8 – 4 15/16"

BALDOR
A MEMBER OF THE ABB GROUP

P.O. Box 2400, Fort Smith, AR 72902-2400 U.S.A., Ph: (1) 479.646.4711, Fax (1) 479.648.5792, International Fax (1) 479.648.5895

Baldor - Dodge

6040 Ponders Court, Greenville, SC 29615-4617 U.S.A., Ph: (1) 864.297.4800, Fax: (1) 864.281.2433

www.baldor.com