

1 Series

- Wood Furniture Stem
- Capacity up to 75 lbs each

www.colsoncaster.com

Standard Features

- Zinc plated finish is attractive and durable
- Full double ball hardened raceways for better performance and greater durability
- $\frac{5}{16}$ " shouldered axle with $\frac{1}{4}$ " nut
- "Colson 45" multi-temp grease lubricates in extreme hot and cold temperatures

Standard Mounting

- For use on wood furniture that can accept a $\frac{3}{8}$ " diameter hole approximately $1\frac{5}{8}$ " deep
- Stem size: $\frac{5}{16}$ " diameter x $1\frac{1}{2}$ " long
- Standard No.20 pressed steel adapter (Part #50011) with toothed base is supplied



Standard Dimensions

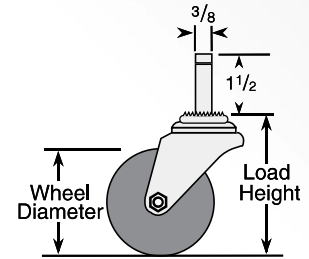

Swivel Cross Section

Fork Leg Spacing $1\frac{5}{32}$ "

Colson 1 Series Casters • Wood Furniture Stem • Capacity to 75 lbs

Wheel Dia.	Tread Width	Capacity Each (Pounds)	Wheel Descriptions	Wheel Bearing	Stem Caster Models	Load Height	Swivel Radius	Weight (Pounds)
1 $\frac{5}{8}$ "	7/8"	60	Perfoma Rubber	Delrin	1.01652.441	2 $\frac{1}{2}$	1 $\frac{3}{4}$	1/2
		75	Polyolefin	Delrin	1.01652.52	2 $\frac{1}{2}$	1 $\frac{3}{4}$	1/2
2"	7/8"	75	Perfoma Rubber	Delrin	1.02252.441	2 $\frac{11}{16}$	1 $\frac{15}{16}$	1/2
			Polyolefin	Delrin	1.02252.52	2 $\frac{11}{16}$	1 $\frac{15}{16}$	1/2
			Cushion Rubber	Ball	1.02252.45	2 $\frac{11}{16}$	1 $\frac{15}{16}$	1/2
			Hard Rubber	Ball	1.02252.55	2 $\frac{11}{16}$	1 $\frac{15}{16}$	1/2
3"	7/8"	75	Perfoma Rubber	Delrin	1.03052.441	3 $\frac{13}{16}$	2 $\frac{9}{16}$	3/4
			Polyurethane HITECH	Delrin	1.03052.91	3 $\frac{13}{16}$	2 $\frac{9}{16}$	3/4
			Polyolefin	Delrin	1.03052.53	3 $\frac{13}{16}$	2 $\frac{9}{16}$	3/4

Caster Brake



Side Lock
(See page 14) Available on all 3" models. Field installable (Specify **BRK3**).

Fork Option



NSF Listed
(See page 3) All models except thread guards (Specify **FSI**).

Wheel Option

Thread Guards
(See page 114) Available on some models. Brake & NSF options cannot be used with thread guards (Specify **TG1** for metal or **TG2** for plastic).

Wheel Selection



1 Series

- Expanding Stem Adapter
- Capacity up to 145 lbs each

www.colsoncaster.com

Standard Dimensions

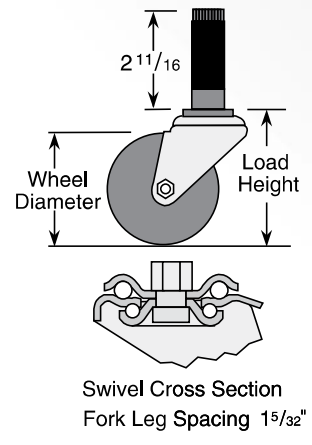

1 Series

Colson®

Standard Features

- Zinc plated finish is attractive and durable
- Full double ball hardened raceways for better performance and greater durability
- 5/16" shouldered axle with 1/4" nut
- "Colson 45" multi-temp grease lubricates in extreme hot and cold temperatures

Standard Mounting

- Turning of octagon on upper raceway expands rubber adapter inside of round or square tubing for a tight, permanent fit
- To order, select caster model number and specify stem adapter size by code number from mounting options chart at bottom right



Colson 1 Series Casters • Expanding Stem Adapter • Capacity to 145 lbs each

Wheel Dia.	Tread Width	Capacity Each (Pounds)	Wheel Descriptions	Wheel Bearing	Stem Caster Models	Load Height	Swivel Radius	Weight (Pounds)
3"	7/8"	100	Polyurethane HI-TECH	Delrin	1.03367.91	3 ⁷ / ₈	2 ¹³ / ₁₆	1 ¹ / ₄
		125	Performa Rubber	Delrin	1.03367.441	3 ⁷ / ₈	2 ¹³ / ₁₆	1 ¹ / ₄
			Polyolefin	Delrin	1.03367.53	3 ⁷ / ₈	2 ¹³ / ₁₆	1 ¹ / ₄
4"	7/8"	125	Polyurethane HI-TECH	Delrin	1.04367.91	4 ⁷ / ₈	3 ⁷ / ₁₆	1 ¹ / ₂
		135	Performa Rubber	Delrin	1.04367.441	4 ⁷ / ₈	3 ⁷ / ₁₆	1 ¹ / ₂
			Polyolefin	Delrin	1.04367.53	4 ⁷ / ₈	3 ⁷ / ₁₆	1 ¹ / ₂
5"	7/8"	140	Polyurethane HI-TECH	Delrin	1.05367.91	5 ⁷ / ₈	4 ¹ / ₁₆	1 ³ / ₄
		145	Performa Rubber	Delrin	1.05367.441	5 ⁷ / ₈	4 ¹ / ₁₆	1 ³ / ₄
			Polyolefin	Delrin	1.05367.53	5 ⁷ / ₈	4 ¹ / ₁₆	1 ³ / ₄

Note: Expanding adapter temperature rating is at 180°F.

Caster Brake



Side Lock (See page 14)
Available on all models. Field installable (Specify **BRK3**).

Wheel Option

Thread Guards
(See page 114) Available on some models. Brake & NSF options cannot be used with thread guards (Specify **TG1** for metal or **TG2** for plastic).

Fork Option



NSF Listed
(See page 3) All models except thread guards (Specify **FS1**).

Wheel Selection



Mounting Options

(See page 115)

Inside Diameter of Tube	Mounting Code Numbers	
	Round Tubing	Square Tubing
3/4" - 13/16"	MTG40	-
7/8" - 15/16"	MTG41	MTG51
1" - 1 1/16"	MTG42	MTG52
1 1/8" - 1 3/16"	MTG43	MTG53
1 1/4" - 1 5/16"	MTG44	MTG54
1 3/8" - 1 7/16"	MTG45	MTG55
1 1/2" - 1 9/16"	MTG46	-
1 5/8" - 1 11/16"	MTG47	-

Stems are 2¹¹/₁₆" long. Stem size less adapter: 1/2" - 13UNC x 2¹¹/₁₆"

1 Series

- Grip Ring Stem
- Capacity up to 75 lbs each

www.colsoncaster.com

Standard Features

- Zinc plated finish is attractive and durable
- Full double ball hardened raceways for better performance and greater durability
- 5/16" shouldered axle with 1/4" nut
- "Colson 45" multi-temp grease lubricates in extreme hot and cold temperatures

Standard Mounting

- Spring grip on top of stem holds caster firmly in place
- **MTG52:** 7/16" x 1 29/32" long with grip ring



Standard Dimensions

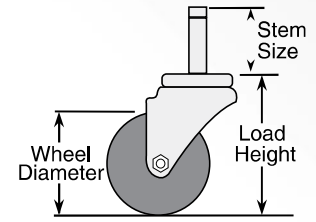

Swivel Cross Section

Fork Leg Spacing 1 5/32"

Colson 1 Series Casters • Grip Ring Stem • Capacity to 75 lbs each

Wheel Dia.	Tread Width	Capacity Each (Pounds)	Wheel Descriptions	Wheel Bearing	Stem Caster Models	Load Height	Swivel Radius	Weight (Pounds)
1 5/8"	7/8"	60	Performa Rubber	Delrin	1.01651.441	2 1/2	1 3/4	1/2
		75	Polyolefin	Delrin	1.01651.52	2 1/2	1 3/4	1/2
2"	7/8"	75	Performa Rubber	Delrin	1.02251.441	2 11/16	1 15/16	1/2
			Polyolefin	Delrin	1.02251.52	2 11/16	1 15/16	1/2
			Cushion Rubber	Ball	1.02251.45	2 11/16	1 15/16	5/8
			Hard Rubber	Ball	1.02251.55	2 11/16	1 15/16	5/8
3"	7/8"	75	Performa Rubber	Delrin	1.03051.441	3 13/16	2 9/16	3/4
			Polyurethane HI-TECH	Delrin	1.03051.91	3 13/16	2 9/16	3/4
			Polyolefin	Delrin	1.03051.53	3 13/16	2 9/16	3/4

Caster Brake



Side Lock
(See page 14) Available on all 3" models. Field installable (Specify **BRK3**).

Wheel Option

Thread Guards
(See page 114) Available on some models. Brake & NSF options cannot be used with thread guards (Specify **TG1** for metal or **TG2** for plastic).

Mounting Options

MTG1: 3/8" x 1 9/16" long
MTG2: 7/16" x 1 9/16" long
MTG50: 7/16" x 1" long
MTG51: 7/16" x 1 29/32" long less grip ring

Fork Option



NSF Listed
(See page 3) All models except thread guards (Specify **FSI**).

Wheel Selection



1 Series

- Grip Ring Stem
- Capacity up to 145 lbs each

Standard Features

- Zinc plated finish is attractive and durable
- Full double ball hardened raceways for better performance and greater durability
- 5/16" shouldered axle with 1/4" nut
- "Colson 45" multi-temp grease lubricates in extreme hot and cold temperatures

Standard Mounting

- Spring grip on top of stem holds caster firmly in place
- **MTG52:** 7/16" x 1 29/32" long **with** grip ring



www.colsoncaster.com

Standard Dimensions

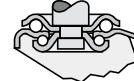
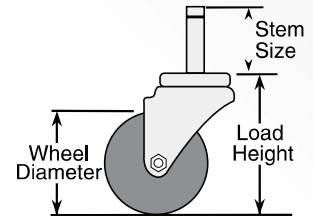

Swivel Cross Section
Fork Leg Spacing 1 5/32"

Colson 1 Series Casters • Grip Ring Stem • Capacity to 145 lbs each

Wheel Dia.	Tread Width	Capacity Each (Pounds)	Wheel Descriptions	Wheel Bearing	Stem Caster Models	Load Height	Swivel Radius	Weight (Pounds)
3"	7/8"	100	Polyurethane HI-TECH	Delrin	1.03351.91	3 3/4	2 13/16	1
		125	Performa Rubber	Delrin	1.03351.441	3 3/4	2 13/16	1 1/8
			Polyolefin	Delrin	1.03351.53	3 3/4	2 13/16	1 1/8
4"	7/8"	125	Polyurethane HI-TECH	Delrin	1.04351.91	4 3/4	3 7/16	1 1/8
		135	Performa Rubber	Delrin	1.04351.441	4 3/4	3 7/16	1 3/8
			Polyolefin	Delrin	1.04351.53	4 3/4	3 7/16	1 3/8
5"	7/8"	140	Polyurethane HI-TECH	Delrin	1.05351.91	5 3/4	4 1/16	1 1/4
		145	Performa Rubber	Delrin	1.05351.441	5 3/4	4 1/16	1 5/8
			Polyolefin	Delrin	1.05351.53	5 3/4	4 1/16	1 1/8

Caster Brake



Side Lock (See page 14)
Available on all models. Field installable (Specify **BRK3**).

Wheel Option

Thread Guards
(See page 114) Available on some models. Brake & NSF options cannot be used with thread guards (Specify **TG1** for metal or **TG2** for plastic).

Mounting Options

MTG2: 7/16" x 1 1/2" long
MTG51: 7/16" x 1 29/32" long **less** grip ring

Wheel Selection

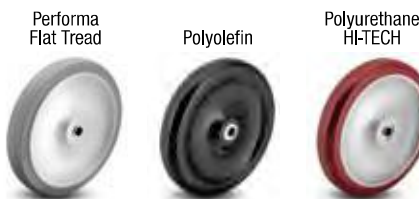

Plastic Adapters

Snap easily in place to reduce distortion and damage to furniture and equipment tubing.

Plastic adapters are non-conductive. First specify **MTG51:** (7/16" x 1 29/32") less grip ring, then specify plastic adapter code from below.

MTG53: (No. 50810): Fits 7/8" x 18 ga. wall round tubing or any I.D. from 3/4" to 51/64".

MTG55: (No. 50865): Fits 1" x 14 ga. wall round tubing or any I.D. from 53/64" to 55/64".

MTG56: (No. 50916): Fits 1" x 16 ga. wall round tubing or any I.D. from 57/64" to 29/32".



Fork Option



NSF Listed
(See page 3) All models except thread guards (Specify **FS1**).

Colson 1 Series

1 Series

- Straight Thread Stem
- Capacity up to 75 lbs each

www.colsoncaster.com

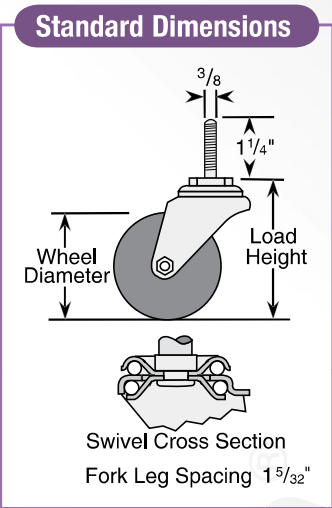

- Standard Features**
- Zinc plated finish is attractive and durable
 - Full double ball hardened raceways for better performance and greater durability
 - 5/16" shouldered axle with 1/4" nut
 - "Colson 45" multi-temp grease lubricates in extreme hot and cold temperatures

- Standard Mounting**
- **MTG55:** 3/8" diameter- 16UNC x 1 1/4" long threaded 1 1/8"

IMPORTANT: If caster stem is to be screwed into customer equipment, the customer must add a washer to the stem that will cover the incomplete threads and support the upper race. The stem shoulder must fit tightly against the customer equipment.

Colson 1 Series Casters • Straight Thread Stem • Capacity to 75 lbs each

Wheel Dia.	Tread Width	Capacity Each (Pounds)	Wheel Descriptions	Wheel Bearing	Stem Caster Models	Load Height	Swivel Radius	Weight (Pounds)
1 5/8"	7/8"	60	Perfoma Rubber	Delrin	1.01654.441	2 1/2	1 3/4	3/8
		75	Polyolefin	Delrin	1.01654.52	2 1/2	1 3/4	3/8
2"	7/8"	75	Perfoma Rubber	Delrin	1.02254.441	2 11/16	1 15/16	3/8
			Polyolefin	Delrin	1.02254.52	2 11/16	1 15/16	3/8
			Cushion Rubber	Ball	1.02254.45	2 11/16	1 15/16	1/2
			Hard Rubber	Ball	1.02254.55	2 11/16	1 15/16	1/2
3"	7/8"	75	Perfoma Rubber	Delrin	1.03054.441	3 13/16	2 9/16	5/8
			Polyurethane HITECH	Delrin	1.03054.91	3 13/16	2 9/16	5/8
			Polyolefin	Delrin	1.03054.53	3 13/16	2 9/16	5/8

Caster Brake



Side Lock
(See page 14) Available on all 3" models. Field installable (Specify **BRK3**).

Wheel Option

Thread Guards
(See page 114) Available on some models. Brake & NSF options cannot be used with thread guards (Specify **TG1** for metal or **TG2** for plastic).

Mounting Options

MTG51: 3/8" diameter - 24NF x 1 1/16" long

Fork Option



NSF Listed
(See page 3) All models except thread guards (Specify **FSI**).

Wheel Selection



1 Series

- Straight Thread Stem
- Capacity up to 145 lbs each

www.colsoncaster.com



Standard Dimensions

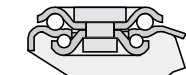
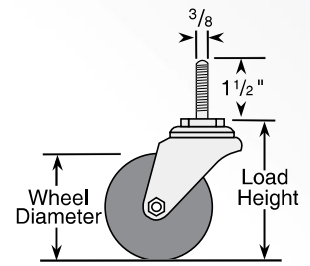

Swivel Cross Section
Fork Leg Spacing 1 5/32"

1 Series

COLSON®

Standard Features

- Zinc plated finish is attractive and durable
- Full double ball hardened raceways for better performance and greater durability
- 5/16" shouldered axle with 1/4" nut
- "Colson 45" multi-temp grease lubricates in extreme hot and cold temperatures

Standard Mounting

- 3/8" diameter - 16UNC x 1 1/2" long threaded 1 3/8"

IMPORTANT: If caster stem is to be screwed into customer equipment, the customer must add a washer to the stem that will cover the incomplete threads and support the upper race. The stem shoulder must fit tightly against the customer equipment.

Colson 1 Series Casters • Straight Thread Stem • Capacity to 145 lbs each

Wheel Dia.	Tread Width	Capacity Each (Pounds)	Wheel Descriptions	Wheel Bearing	Stem Caster Models	Load Height	Swivel Radius	Weight (Pounds)
3"	7/8"	100	Polyurethane HI-TECH	Delrin	1.03354.91	3 ³ / ₄	2 ¹³ / ₁₆	1 ¹ / ₈
		125	Performa Rubber	Delrin	1.03354.441	3 ³ / ₄	2 ¹³ / ₁₆	1 ¹ / ₈
			Polyolefin	Delrin	1.03354.53	3 ³ / ₄	2 ¹³ / ₁₆	1 ¹ / ₈
4"	7/8"	125	Polyurethane HI-TECH	Delrin	1.04354.91	4 ³ / ₄	3 ⁷ / ₁₆	1 ³ / ₈
		135	Performa Rubber	Delrin	1.04354.441	4 ³ / ₄	3 ⁷ / ₁₆	1 ³ / ₈
			Polyolefin	Delrin	1.04354.53	4 ³ / ₄	3 ⁷ / ₁₆	1 ³ / ₈
5"	7/8"	140	Polyurethane HI-TECH	Delrin	1.05354.91	5 ³ / ₄	4 ¹ / ₁₆	1 ⁵ / ₈
		145	Performa Rubber	Delrin	1.05354.441	5 ³ / ₄	4 ¹ / ₁₆	1 ⁵ / ₈
			Polyolefin	Delrin	1.05354.53	5 ³ / ₄	4 ¹ / ₁₆	1 ⁵ / ₈

Caster Brake



Side Lock (See page 14)
Available on all models. Field installable (Specify **BRK3**).

Wheel Option

Thread Guards
(See page 114) Available on some models. Brake & NSF options cannot be used with thread guards (Specify **TG1** for metal or **TG2** for plastic).

Fork Option



NSF Listed
(See page 3) All models except thread guards (Specify **FS1**).

Wheel Selection



1 Series

- Square Stem
- Capacity up to 145 lbs each

www.colsoncaster.com

Standard Features

- Zinc plated finish is attractive and durable
- Full double ball hardened raceways for better performance and greater durability
- 5/16" shouldered axle with 1/4" nut
- "Colson 45" multi-temp grease lubricates in extreme hot and cold temperatures

Standard Mounting

- Designed for easy installation on the inside of angle iron legs or against flat surfaces
- Stems may be bolted or riveted against any flat vertical surface
- Standard Stem 2" long by 3/4" square with 3 mounting holes 17/64" diameter



Standard Dimensions

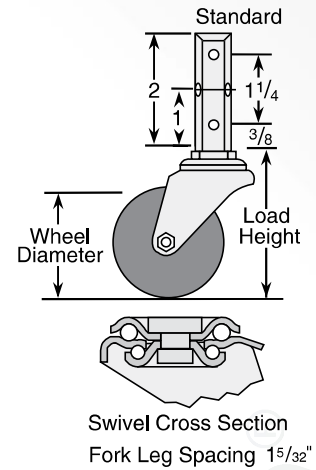

Colson 1 Series Casters • Square Stem • Capacity to 145 lbs each

Wheel Dia.	Tread Width	Capacity Each (Pounds)	Wheel Descriptions	Wheel Bearing	Stem Caster Models	Load Height	Swivel Radius	Weight (Pounds)
3"	7/8"	100	Polyurethane HI-TECH	Delrin	1.03370.91	3 3/4	2 13/16	1 1/4
		125	Performa Rubber	Delrin	1.03370.441	3 3/4	2 13/16	1 1/4
			Polyolefin	Delrin	1.03370.53	3 3/4	2 13/16	1 1/4
4"	7/8"	125	Polyurethane HI-TECH	Delrin	1.04370.91	4 3/4	3 7/16	1 1/2
		135	Performa Rubber	Delrin	1.04370.441	4 3/4	3 7/16	1 1/2
			Polyolefin	Delrin	1.04370.53	4 3/4	3 7/16	1 1/2
5"	7/8"	140	Polyurethane HI-TECH	Delrin	1.05370.91	5 3/4	4 1/16	1 3/4
			Performa Rubber	Delrin	1.05370.441	5 3/4	4 1/16	1 3/4
			Polyolefin	Delrin	1.05370.53	5 3/4	4 1/16	1 3/4

Caster Brake



Side Lock
(See page 14) Available on all models. Field installable (Specify **BRK3**).

Fork Option



NSF Listed
(See page 3) All models except thread guards (Specify **FS1**).

Wheel Option

Thread Guards
(See page 114) Available on some models. Brake & NSF options cannot be used with thread guards (Specify **TG1** for metal or **TG2** for plastic).

Wheel Selection

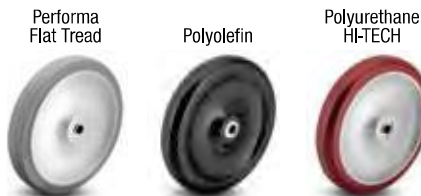

Mounting Options

MTG1: Optional Square Stem: 2" long x 7/8" square with 1 mounting hole 17/64" diameter.

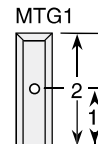

1 Series

- Small Top Plate Swivel and Rigid
- Capacity up to 75 lbs each

www.colsoncaster.com

1 Series

Standard Features

- Zinc plated finish is attractive and durable
- Full double ball hardened raceways for better performance and greater durability
- $\frac{5}{16}$ " shouldered axle with $\frac{1}{4}$ " nut
- "Colson 45" multi-temp grease lubricates in extreme hot and cold temperatures

Standard Mounting

- Rigid caster mounting holes do not match swivel



Standard Dimensions

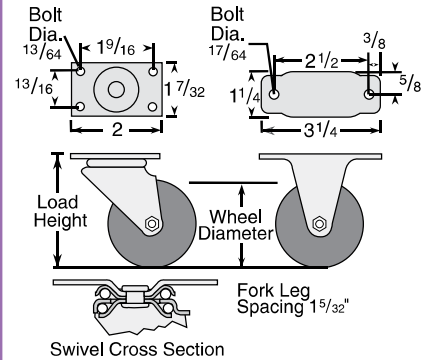

Colson 1 Series Casters • Small Top Plate Swivel and Rigid • Capacity to 75 lbs each

Wheel Dia.	Tread Width	Capacity Each (Pounds)	Wheel Descriptions	Wheel Bearing	Swivel Top Plate Caster Models	Rigid Top Plate Caster Models	Load Height	Swivel Radius	Weight (Pounds)
1 5/8"	7/8"	60	Performa Rubber	Delrin	1.01666.441	1.01610.441	2 9/16	1 3/4	3/8
		75	Polyolefin	Delrin	1.01666.52	1.01610.52	2 9/16	1 3/4	3/8
2"	7/8"	75	Performa Rubber	Delrin	1.02266.441	1.02210.441	2 3/4	1 15/16	1/2
			Polyolefin	Delrin	1.02266.52	1.02210.52	2 3/4	1 15/16	1/2
			Cushion Rubber	Ball	1.02266.45	1.02210.45	2 3/4	1 15/16	1/2
			Hard Rubber	Ball	1.02266.55	1.02210.55	2 3/4	1 15/16	1/2
3"	7/8"	75	Performa Rubber	Delrin	1.03066.441	—	3 7/8	2 9/16	3/4
			Polyurethane HI-TECH	Delrin	1.03066.91	—	3 7/8	2 9/16	3/4
			Polyolefin	Delrin	1.03066.53	—	3 7/8	2 9/16	3/4

Caster Brake



Side Lock (See page 14)
Available on all 3" swivel models. Field installable (Specify **BRK3**).

Wheel Option

Thread Guards
(See page 114) Available on some models. Brake & NSF options cannot be used with thread guards (Specify **TG1** for metal or **TG2** for plastic).

Fork Option



NSF Listed
(See page 3) All models except thread guards (Specify **FS1**).

Wheel Selection



1 Series

- Top Plate Swivel and Rigid
- Capacity up to 75 lbs each

www.colsoncaster.com

Standard Features

- Zinc plated finish is attractive and durable
- Full double ball hardened raceways for better performance and greater durability
- $\frac{5}{16}$ " shouldered axle with $\frac{1}{4}$ " nut
- "Colson 45" multi-temp grease lubricates in extreme hot and cold temperatures

Standard Mounting

- Rigid caster available with 3" diameter wheel only



Standard Dimensions

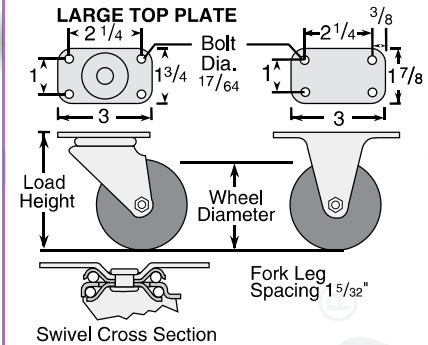

Colson 1 Series Casters • Top Plate Swivel and Rigid • Capacity to 75 lbs each

Wheel Dia.	Tread Width	Capacity Each (Pounds)	Wheel Descriptions	Wheel Bearing	Swivel Top Plate Caster Models	Rigid Top Plate Caster Models	Load Height	Swivel Radius	Weight (Pounds)
1 5/8"	7/8"	60	Performa Rubber	Delrin	1.01656.441	—	2 9/16	1 3/4	1/2
		75	Polyolefin	Delrin	1.01656.52	—	2 9/16	1 3/4	1/2
2"	7/8"	75	Performa Rubber	Delrin	1.02256.441	—	2 3/4	1 15/16	1/2
			Polyolefin	Delrin	1.02256.52	—	2 3/4	1 15/16	1/2
			Cushion Rubber	Ball	1.02256.45	—	2 3/4	1 15/16	5/8
			Hard Rubber	Ball	1.02256.55	—	2 3/4	1 15/16	5/8
3"	7/8"	75	Performa Rubber	Delrin	1.03056.441	1.03010.441	3 7/8	2 9/16	3/4
			Polyurethane HI-TECH	Delrin	1.03056.91	1.03010.91	3 7/8	2 9/16	3/4
			Polyolefin	Delrin	1.03056.53	1.03010.53	3 7/8	2 9/16	3/4

Caster Brake



Side Lock
(See page 14) Available on all 3" swivel models. Field installable (Specify **BRK3**).

Fork Option



NSF Listed
(See page 3) All models except thread guards (Specify **FS1**).

Wheel Option

Thread Guards
(See page 114) Available on some models. Brake & NSF options cannot be used with thread guards (Specify **TG1** for metal or **TG2** for plastic).

Wheel Selection



1 Series

- Large Top Plate Swivel and Rigid
- Capacity up to 145 lbs each

www.colsoncaster.com

1 Series

COLSON®

Standard Features

- Zinc plated finish is attractive and durable
- Full double ball hardened raceways for better performance and greater durability
- $\frac{5}{16}$ " shouldered axle with $\frac{1}{4}$ " nut
- .090" steel top plate
- "Colson 45" multi-temp grease lubricates in extreme hot and cold temperatures



Standard Dimensions

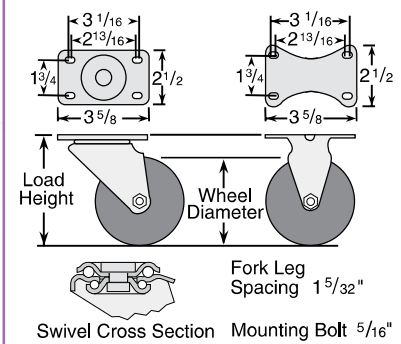

Colson 1 Series Casters • Large Top Plate Swivel and Rigid • Capacity to 145 lbs each

Wheel Dia.	Tread Width	Capacity Each (Pounds)	Wheel Descriptions	Wheel Bearing	Swivel Top Plate Caster Models	Rigid Top Plate Caster Models	Load Height	Swivel Radius	Weight (Pounds)
3"	$\frac{7}{8}$ "	100	Polyurethane HI-TECH	Delrin	1.03356.91	1.03008.91	$3\frac{3}{4}$	$2\frac{13}{16}$	$1\frac{1}{4}$
		125	Performa Rubber	Delrin	1.03356.441	1.03008.441	$3\frac{3}{4}$	$2\frac{13}{16}$	$1\frac{1}{4}$
			Polyolefin	Delrin	1.03356.53	1.03008.53	$3\frac{3}{4}$	$2\frac{13}{16}$	$1\frac{1}{4}$
4"	$\frac{7}{8}$ "	125	Polyurethane HI-TECH	Delrin	1.04356.91	1.04008.91	$4\frac{3}{4}$	$3\frac{7}{16}$	$1\frac{1}{2}$
		135	Performa Rubber	Delrin	1.04356.441	1.04008.441	$4\frac{3}{4}$	$3\frac{7}{16}$	$1\frac{1}{2}$
			Polyolefin	Delrin	1.04356.53	1.04008.53	$4\frac{3}{4}$	$3\frac{7}{16}$	$1\frac{1}{2}$
5"	$\frac{7}{8}$ "	140	Polyurethane HI-TECH	Delrin	1.05356.91	1.05008.91	$5\frac{3}{4}$	$4\frac{1}{16}$	$1\frac{3}{4}$
		145	Performa Rubber	Delrin	1.05356.441	1.05008.441	$5\frac{3}{4}$	$4\frac{1}{16}$	$1\frac{3}{4}$
			Polyolefin	Delrin	1.05356.53	1.05008.53	$5\frac{3}{4}$	$4\frac{1}{16}$	$1\frac{3}{4}$

Caster Brake



Side Lock
(See page 14) Available on all swivel models. Field installable (Specify **BRK3**).

Wheel Option

Thread Guards
(See page 114) Available on some models. Brake & NSF options cannot be used with thread guards (Specify **TG1** for metal or **TG2** for plastic).

Fork Option



NSF Listed
(See page 3) All models except thread guards (Specify **FS1**).

Wheel Selection





Light Duty Casters Series

- Top Plate Swivel and Rigid
- Threaded Stem
- Grip Ring Stem
- Capacity up to 150 lbs each

www.colsoncaster.com



Standard Features

- Zinc plated finish is attractive and durable
- Full double ball hardened raceways for better performance and greater durability
- Standard models feature riveted axle; brake models feature nut and bolt
- All models NSF approved and RoHS compliant

Standard Dimensions

Top Plate (LTP)

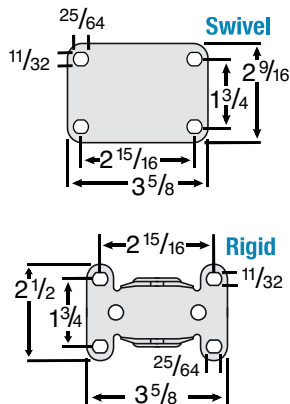

Threaded Stem (LTS)

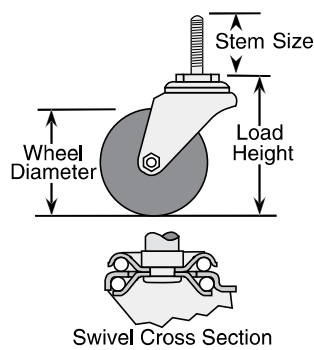

Grip Ring Stem (LGR)

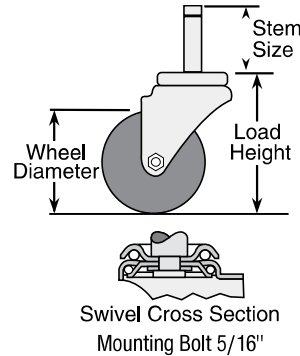

Caster Brake



Side Lock
(See page 14) Available on LTS and LGR casters for 2" models only. Brake is not field installable. To order with caster, add "001" to the end of the part number (Example: LGR0251242**001**).



Top Lock
(See page 14) Available on 3", 4", and 5" models for all L Series products—LTP (Swivel Only), LGS and LGR casters. Brake is not field installable. To order with caster, add "001" to the end of the part number (Example: LGR3351242**001**).

Fork Option



NSF Listed
(See page 3) All models NSF approved.

Wheel Selection

Polyolefin



TPR





Colson L Series LTP Casters • Top Plate Swivel and Rigid • Capacity to 150 lbs

Wheel Dia.	Tread Width	Capacity Each (Pounds)	Wheel Descriptions	Wheel Bearing	Swivel Top Plate Models	Rigid Top Plate Models	Load Height	Swivel Radius	Weight (Pounds)
3"	13/16"	90	TPR	Plain	LTP3356142	LTP3308142	3 3/4	2 3/4	3/4
		110	Polyolefin	Plain	LTP3356152	LTP3308152	3 3/4	2 3/4	3/4
4"	15/16"	115	TPR	Plain	LTP0456142	LTP0408142	4 13/16	3 5/16	1
		140	Polyolefin	Plain	LTP0456152	LTP0408152	4 13/16	3 5/16	1
5"	15/16"	125	TPR	Plain	LTP0556142	LTP0508142	5 13/16	3 5/16	1 1/4
		150	Polyolefin	Plain	LTP0556152	LTP0508152	5 13/16	3 5/16	1 1/4



Colson L Series LTS Casters • Threaded Stem • Capacity to 150 lbs

Wheel Dia.	Tread Width	Capacity Each (Pounds)	Wheel Descriptions	Wheel Bearing	Threaded Stem Caster Models	Load Height	Swivel Radius	Weight (Pounds)	Stem Size
2"	3/4"	80	TPR	Plain	LTS0254542	2 17/32	1 13/16	1/4	3/8" dia. 16NC x 1 1/2" long
3"	13/16"	90	TPR	Plain	LTS3354542	3 1/2	2 19/32	3/4	3/8" dia. 16NC x 1 1/2" long
		110	Polyolefin	Plain	LTS3354552	3 1/2	2 19/32	3/4	
4"	15/16"	115	TPR	Plain	LTS0454342	4 11/16	3 9/32	1	1/2" dia. 13NC x 1 1/2" long
		140	Polyolefin	Plain	LTS0454352	4 11/16	3 9/32	1	
5"	15/16"	125	TPR	Plain	LTS0554342	5 23/32	3 3/4	1 1/4	1/2" dia. 13NC x 1 1/2" long
		150	Polyolefin	Plain	LTS0554352	5 23/32	3 3/4	1 1/4	



Colson L Series LGR Casters • Grip Ring • Capacity to 150 lbs

Wheel Dia.	Tread Width	Capacity Each (Pounds)	Wheel Descriptions	Wheel Bearing	Grip Ring Stem Caster Models	Load Height	Swivel Radius	Weight (Pounds)	Stem Size
2"	3/4"	80	TPR	Plain	LGR0251242	2 17/32	1 13/16	1/4	7/16" dia. x 1 3/8" long
3"	13/16"	90	TPR	Plain	LGR3351242	3 1/2	2 19/32	3/4	7/16" dia. x 1 3/8" long
		110	Polyolefin	Plain	LGR3351252	3 1/2	2 19/32	3/4	
4"	15/16"	115	TPR	Plain	LGR0451342	4 5/8	3 9/32	1	7/16" dia. x 1 17/32" long
		140	Polyolefin	Plain	LGR0451352	4 5/8	3 9/32	1	
5"	15/16"	125	TPR	Plain	LGR0551342	5 5/8	3 3/4	1 1/4	7/16" dia. x 1 17/32" long
		150	Polyolefin	Plain	LGR0551352	5 5/8	3 3/4	1 1/4	